

NuDAM-6050 NuDAM-6052

NuDAM-6053 NuDAM-6054

NuDAM-6056 NuDAM-6058

NuDAM-6060 NuDAM-6063

Digital I/O Modules



Recycled Paper

© Copyright 1995~2001 ADLINK Technology Inc.

All Rights Reserved.

Manual Rev. 3.51: March 27, 2001

Part No : 50-12003-201

The information in this document is subject to change without prior notice in order to improve reliability, design and function and does not represent a commitment on the part of the manufacturer.

In no event will the manufacturer be liable for direct, indirect, special, incidental, or consequential damages arising out of the use or inability to use the product or documentation, even if advised of the possibility of such damages.

This document contains proprietary information protected by copyright. All rights are reserved. No part of this manual may be reproduced by any mechanical, electronic, or other means in any form without prior written permission of the manufacturer.

Trademarks

ND-6050, ND-6052, ND-6053, ND-6054, ND-6056, ND6058, ND-6060 and ND-6063 are registered trademarks of ADLink Technology Inc., IBM PC is a registered trademark of International Business Machines Corporation. Intel is a registered trademark of Intel Corporation. Other product names mentioned herein are used for identification purposes only and may be trademarks and/or registered trademarks of their respective companies.

Getting service from ADLINK

- ◆ Customer Satisfaction is always the most important thing for ADLINK Tech Inc. If you need any help or service, please contact us and get it.

| ADLINK Technology Inc. | | |
|------------------------|---|---------------------|
| Web Site | http://www.adlink.com.tw http://www.adlinktechnology.co | |
| Sales & Service | service@Adlink.com.tw | |
| Technical Support | NuDAQ | nudaq@adlink.com.tw |
| | NuDAM | nudam@adlink.com.tw |
| | NuIPC | nuipc@adlink.com.tw |
| | NuPRO | nupro@adlink.com.tw |
| | Software | sw@adlink.com.tw |
| TEL | +886-2-82265877 | FAX +886-2-82265717 |
| Address | 9F, No. 166, Jian Yi Road, Chungho City, Taipei, 235 Taiwan, R.O.C. | |

- ◆ Please inform or FAX us of your detailed information for a prompt, satisfactory and constant service.

| Detailed Company Information | | |
|------------------------------|--|-----|
| Company/Organization | | |
| Contact Person | | |
| E-mail Address | | |
| Address | | |
| Country | | |
| TEL | | FAX |
| Web Site | | |
| Questions | | |
| Product Model | | |
| Environment to Use | <input type="checkbox"/> OS: _____ <input type="checkbox"/> Computer Brand: _____ <input type="checkbox"/> M/B: _____ <input type="checkbox"/> CPU: _____ <input type="checkbox"/> Chipset: _____ <input type="checkbox"/> BIOS: _____ <input type="checkbox"/> Video Card: <input type="checkbox"/> Network Interface Card: <input type="checkbox"/> Other: | |
| Challenge Description | | |
| Suggestions for ADLINK | | |

Table of Contents

| | |
|---|----------|
| Chapter 1 Introduction | 1 |
| 1.1 About the NuDAM DIO Modules | 1 |
| 1.2 Overview of NuDAM-6050 | 2 |
| 1.2.1 <i>What is NuDAM-6050?</i> | 2 |
| 1.2.2 <i>Features of NuDAM-6050</i> | 2 |
| 1.2.3 <i>Specifications of NuDAM-6050</i> | 2 |
| 1.2.4 <i>A Look at ND-6050 & Pin Assignment</i> | 4 |
| 1.2.5 <i>Pin Definitions of NuDAM-6050</i> | 5 |
| 1.2.6 <i>ND-6050 Functional Block Diagram</i> | 6 |
| 1.3 Overview of NuDAM-6052 | 7 |
| 1.3.1 <i>What is NuDAM-6052 ?</i> | 7 |
| 1.3.2 <i>Features of NuDAM-6052</i> | 7 |
| 1.3.3 <i>Specifications of NuDAM-6052</i> | 7 |
| 1.3.4 <i>A Look at ND-6052 & Pin Assignment</i> | 9 |
| 1.3.5 <i>Pin Definitions of NuDAM-6052</i> | 10 |
| 1.3.6 <i>ND-6052 Functional Block Diagram</i> | 11 |
| 1.4 Overview of NuDAM-6053 | 12 |
| 1.4.1 <i>What is NuDAM-6053 ?</i> | 12 |
| 1.4.2 <i>Features of NuDAM-6053</i> | 12 |
| 1.4.3 <i>Specifications of NuDAM-6053</i> | 12 |
| 1.4.4 <i>A Look at ND-6053 & Pin Assignment</i> | 14 |
| 1.4.5 <i>Pin Definitions of NuDAM-6053</i> | 15 |
| 1.4.6 <i>ND-6053 Functional Block Diagram</i> | 16 |
| 1.5 Overview of NuDAM-6054 | 17 |
| 1.5.1 <i>What is NuDAM-6054 ?</i> | 17 |
| 1.5.2 <i>Features of NuDAM-6054</i> | 17 |
| 1.5.3 <i>Specifications of NuDAM-6054</i> | 17 |
| 1.5.4 <i>A Look at ND-6054 & Pin Assignment</i> | 19 |
| 1.5.5 <i>Pin Definitions of NuDAM-6054</i> | 20 |
| 1.5.6 <i>ND-6054 Functional Block Diagram</i> | 21 |
| 1.6 Overview of NuDAM-6056 | 22 |
| 1.6.1 <i>What is NuDAM-6056 ?</i> | 22 |
| 1.6.2 <i>Features of NuDAM-6056</i> | 22 |
| 1.6.3 <i>Specifications of NuDAM-6056</i> | 22 |
| 1.6.4 <i>A Look at ND-6056 & Pin Assignment</i> | 24 |
| 1.6.5 <i>Pin Definitions of NuDAM-6056</i> | 24 |
| 1.6.5 <i>Pin Definitions of NuDAM-6056</i> | 25 |
| 1.6.6 <i>ND-6056 Functional Block Diagram</i> | 26 |

| | | |
|-------|---|----|
| 1.7 | Overview of NuDAM-6058 | 27 |
| 1.7.1 | What is NuDAM-6058 ? | 27 |
| 1.7.2 | Features of NuDAM-6058..... | 27 |
| 1.7.3 | Specifications of NuDAM-6058 | 28 |
| 1.7.4 | A Look at ND-6058 & Pin Assignment..... | 30 |
| 1.7.5 | Pin Definitions of NuDAM-6058 | 31 |
| 1.7.6 | ND-6058 Functional Block Diagram..... | 32 |
| 1.8 | Overview of NuDAM-6060 | 33 |
| 1.8.1 | What is NuDAM-6060 ? | 33 |
| 1.8.2 | Features of NuDAM-6060..... | 33 |
| 1.8.3 | Specifications of NuDAM-6060 | 33 |
| 1.8.4 | Using Relay Output..... | 35 |
| 1.8.5 | A Look at ND-6060 & Pin Assignment..... | 36 |
| 1.8.6 | Pin Definitions of NuDAM-6060 | 37 |
| 1.8.7 | ND-6060 Functional Block Diagram..... | 38 |
| 1.9 | Overview of NuDAM-6063 | 39 |
| 1.9.1 | What is NuDAM-6063 ? | 39 |
| 1.9.2 | Features of NuDAM-6063..... | 39 |
| 1.9.3 | Specifications of NuDAM-6063 | 39 |
| 1.9.4 | Using Relay Output..... | 40 |
| 1.9.5 | A Look at ND-6063 & Pin Assignment..... | 41 |
| 1.9.6 | Pin Definitions of NuDAM-6063 | 42 |
| 1.9.7 | ND-6063 Functional Block Diagram..... | 43 |

Chapter 2 Initialization & Installation.....44

| | | |
|-------|--|----|
| 2.1 | Software Installation | 44 |
| 2.2 | Initializing a Brand-New Module | 45 |
| 2.2.1 | Objective of Initializing a Brand-New NuDAM..... | 45 |
| 2.2.2 | Default State | 46 |
| 2.2.3 | Initialization Equipments | 47 |
| 2.2.4 | Initialization Procedure | 47 |
| 2.2.5 | Initialization Wiring..... | 48 |
| 2.3 | Install a New NuDAM to a Existing Network..... | 49 |
| 2.3.1 | Equipments for Install a New Module | 49 |
| 2.3.2 | Installing Procedures..... | 49 |
| 2.4 | Application Wiring for NuDAM-6050 | 50 |
| 2.5 | Application Wiring for NuDAM-6052 | 51 |
| 2.6 | Application Wiring for NuDAM-6053 | 52 |
| 2.7 | Application Wiring for NuDAM-6054 | 53 |
| 2.8 | Application Wiring for NuDAM-6056 | 53 |
| 2.9 | Application Wiring for NuDAM-6058 | 54 |

| | | |
|---------------------------------------|---|-----------|
| 2.10 | Application Wiring for NuDAM-6060 | 55 |
| 2.11 | Application Wiring for NuDAM-6063 | 56 |
| Chapter 3 Command Set | | 57 |
| 3.1 | Command and Response | 57 |
| 3.1.1 | <i>Introduction</i> | 57 |
| 3.1.2 | <i>Document Conventions</i> | 58 |
| 3.1.3 | <i>Format of NuDAM Commands</i> | 58 |
| 3.1.4 | <i>Response of NuDAM Commands</i> | 59 |
| 3.2 | Summary of Command Set | 60 |
| 3.3 | Set Configuration | 62 |
| 3.4 | Read Configuration | 64 |
| 3.5 | Read Module Name | 66 |
| 3.6 | Read Firmware Version | 67 |
| 3.7 | Reset Status | 68 |
| 3.8 | Digital Output | 69 |
| 3.9 | Digital Output (Continued) | 71 |
| 3.10 | Digital Output (Continued) | 73 |
| 3.11 | Digital Output (Continued) | 75 |
| 3.12 | Synchronized Sampling | 77 |
| 3.13 | Read Synchronized Data | 78 |
| 3.14 | Digital Input | 81 |
| 3.14 | Programmable I/O Mode Setting | 84 |
| 3.15 | Read Leading Code Setting | 86 |
| 3.16 | Change Leading Code Setting | 88 |
| 3.17 | Set Host Watchdog Timer & Safety Value | 90 |
| 3.18 | Read Host Watchdog Timer & Safety Value | 93 |
| 3.19 | Change Polarity | 95 |
| 3.20 | Read Polarity | 96 |
| 3.21 | Host is OK | 97 |
| Product Warranty/Service | | 98 |



Introduction

1.1 About the NuDAM DIO Modules

The NuDAM provides a series of digital input or output (DIO) modules to sense the digital signal or to control the remote devices.

The specified features of each module are shown here.

- **NuDAM-6050 : Digital I/O module**
- **NuDAM-6052 : Isolated digital input module**
- **NuDAM-6053 : 16-channel digital input module**
- **NuDAM-6054 : 15-channel isolated digital input module**
- **NuDAM-6056 : 15-channel isolated digital output module**
- **NuDAM-6058 : 28 programmable digital I/O module**
- **NuDAM-6060 : relay output and isolated digital input module**
- **NuDAM-6063 : 8-channel relay output module**

1.2 Overview of NuDAM-6050

1.2.1 What is NuDAM-6050?

NuDAM-6050 is a digital input and output module. The digital input channels can monitor active TTL signals, and sense passive switch on/off signal because of the internal pull high resistors. The convenient open collector output channels can sink up to 50 mA current. Combining with the relay devices, it is possible to control the high power devices by programming output channel of the NuDAM-6050.

1.2.2 Features of NuDAM-6050

- ◆ 7 bits digital input
- ◆ 8 bits open collector digital output
- ◆ Programmable host watchdog timer for host failure protection
- ◆ Internal watchdog timer for device failure protection
- ◆ Easy programming by software
- ◆ Easy installation and wiring

1.2.3 Specifications of NuDAM-6050

- ◆ **Interface**
 - Interface : RS-485, 2 wires
 - Speed (bps) : 1200, 2400, 4800, 9600, 19.2K, 38.4K, 115.2K (115.2K only for firmware reversion above A4.00)
- ◆ **Digital Input**
 - Channel numbers : 7
 - Logical level 0 : +1V maximum
 - Logical level 1: +3.5V~30V
 - Pull up resister : 10K Ω
 - Maximum current : 0.5mA

◆ **Digital Output**

- Channel numbers : 8
- Output characteristic : open collector transistor
- Maximum current sink : 50mA
- Max. power dissipation : 300mW

◆ **Watchdog Function**

- Module internal watchdog timer: 150 ms
- Power failure threshold : 4.65 V
- Safety value : 8 output channels
- Host programmable watchdog :
- 100 ms ~ 25.500 sec

◆ **Power**

- Power supply : +10V to +30V
- Current consumption : 0.5 W

1.2.4 A Look at ND-6050 & Pin Assignment

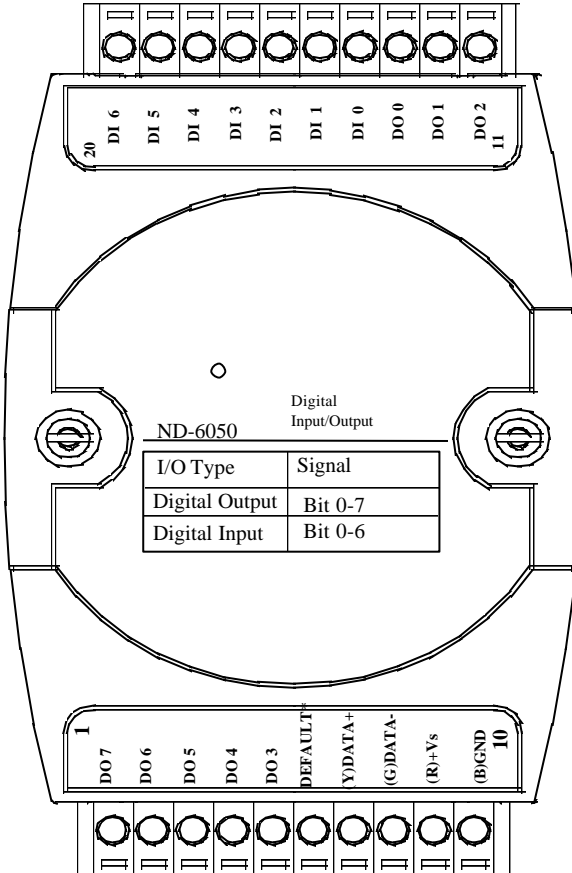

1.2.5 Pin Definitions of NuDAM-6050

| Pin # | Signal Name | Description |
|-------|-------------|--------------------------------|
| 1 | DO 7 | Digital output channel 7 |
| 2 | DO 6 | Digital output channel 6 |
| 3 | DO 5 | Digital output channel 5 |
| 4 | DO 4 | Digital output channel 4 |
| 5 | DO 3 | Digital output channel 3 |
| 6 | Default* | Initial state setting |
| 7 | (Y) DATA+ | RS-485 series signal, positive |
| 8 | (G) DATA- | RS-485 series signal, negative |
| 9 | (R) +Vs | Power supply, +10V~+30V |
| 10 | (B) GND | Ground |
| 11 | DO 2 | Digital output channel 2 |
| 12 | DO 1 | Digital output channel 1 |
| 13 | DO 0 | Digital output channel 0 |
| 14 | DI 0 | Digital input channel 0 |
| 15 | DI 1 | Digital input channel 1 |
| 16 | DI 2 | Digital input channel 2 |
| 17 | DI 3 | Digital input channel 3 |
| 18 | DI 4 | Digital input channel 4 |
| 19 | DI 5 | Digital input channel 5 |
| 20 | DI 6 | Digital input channel 6 |

1.2.6 ND-6050 Functional Block Diagram

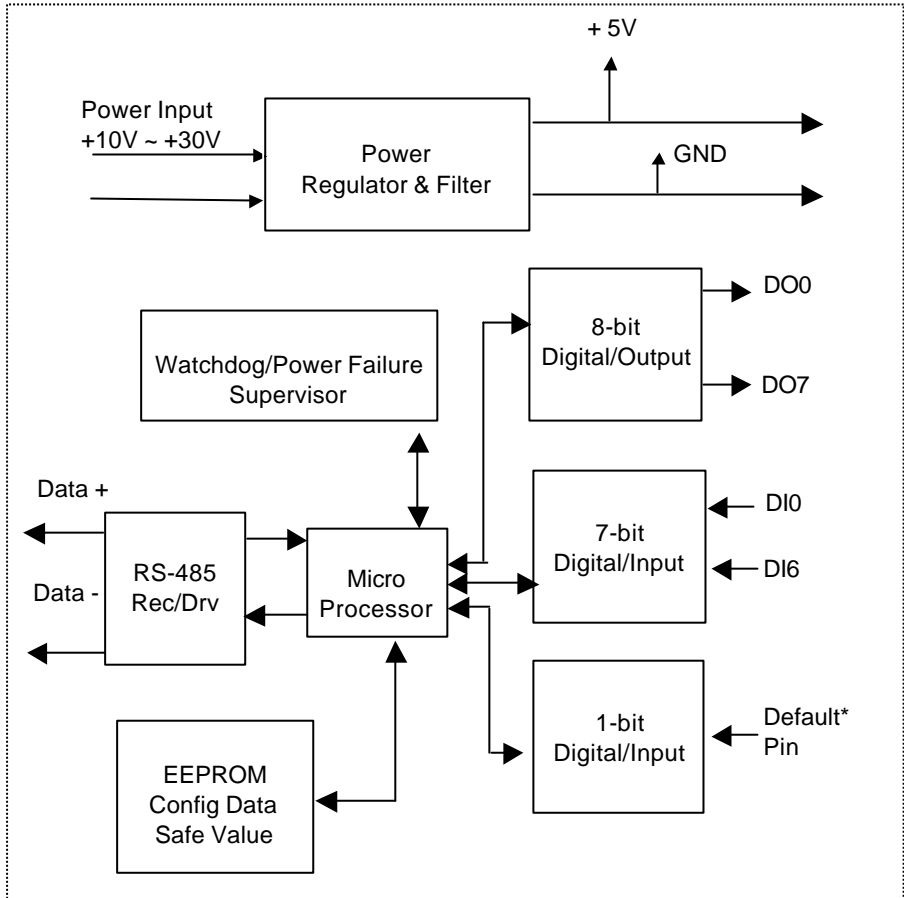

1.3 Overview of NuDAM-6052

1.3.1 What is NuDAM-6052 ?

NuDAM-6052 provides 8 isolated digital input channels. Six of the input channels are differential type and two of them are single-ended with common ground. The isolation voltage is up to 5000 Vrms. It is suitable to use NuDAM-6052 in industrial environment with the dangerous of high voltage electric shock.

1.3.2 Features of NuDAM-6052

- ◆ 8 bits isolated input
- ◆ 5000 Vrms isolation voltage
- ◆ Programmable host watchdog timer for host failure protection
- ◆ Internal watchdog timer for device failure protection
- ◆ Easy programming by software
- ◆ Easy installation and wiring

1.3.3 Specifications of NuDAM-6052

- ◆ **Interface**
 - Interface : RS-485, 2 wires
 - Speed (bps) : 1200, 2400, 4800, 9600, 19.2K, 38.4K, 115.2K (115.2K only for firmware reversion above A4.00)
- ◆ **Input**
 - Channel numbers : 6 differential channels, 2 single ended
 - Logical level 0 : +1V Max.
 - Logical level 1: +3.5V ~ +24V
- ◆ **Watchdog Function**
 - Module internal watchdog timer : 150ms
 - Power failure threshold : 4.65 V

- Safe value : 8 output channels
- Host programmable watchdog : 100 ms ~ 25.5 sec
- ◆ **Power**
 - Power supply : +10V to +30V
 - Current consumption : 0.4 W

1.3.4 A Look at ND-6052 & Pin Assignment

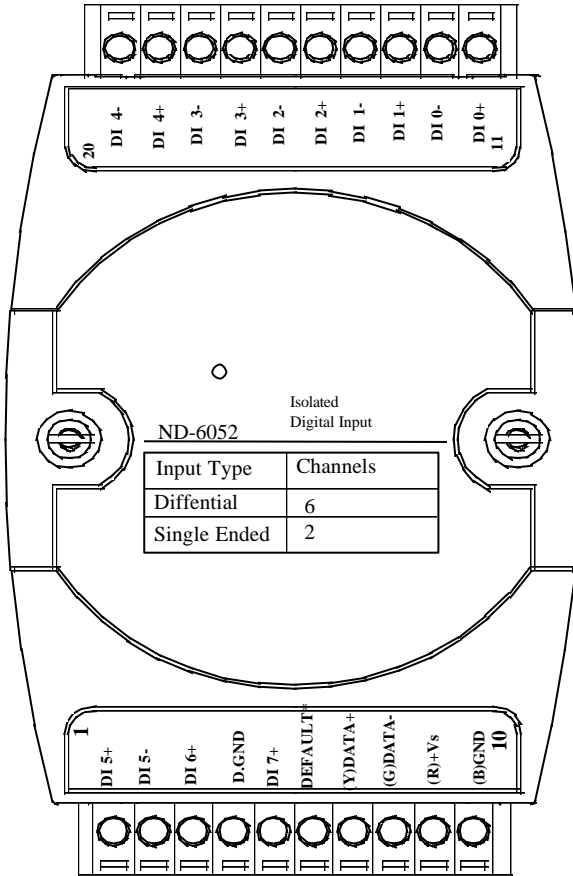

1.3.5 Pin Definitions of NuDAM-6052

| Pin # | Signal Name | Description |
|-------|-------------|--------------------------------|
| 1 | DI5+ | Digital Input Channel 5+ |
| 2 | DI5 - | Digital Input Channel 5 - |
| 3 | DI6+ | Digital Input Channel 6+ |
| 4 | D.GND | Digital Input Ground |
| 5 | DI7+ | Digital Input Channel 7+ |
| 6 | Default* | Initial state setting |
| 7 | (Y) DATA+ | RS-485 series signal, positive |
| 8 | (G) DATA- | RS-485 series signal, negative |
| 9 | (R) +VS | Power supply, +10V~+30V |
| 10 | (B) GND | Ground |
| 11 | DI0+ | Digital Input Channel 0+ |
| 12 | DI0 - | Digital Input Channel 0 - |
| 13 | DI1+ | Digital Input Channel 1+ |
| 14 | DI1 - | Digital Input Channel 1 - |
| 15 | DI2+ | Digital Input Channel 2+ |
| 16 | DI2 - | Digital Input Channel 2 - |
| 17 | DI3+ | Digital Input Channel 3+ |
| 18 | DI3 - | Digital Input Channel 3 - |
| 19 | DI4+ | Digital Input Channel 4+ |
| 20 | DI4 - | Digital Input Channel 4 - |

1.3.6 ND-6052 Functional Block Diagram

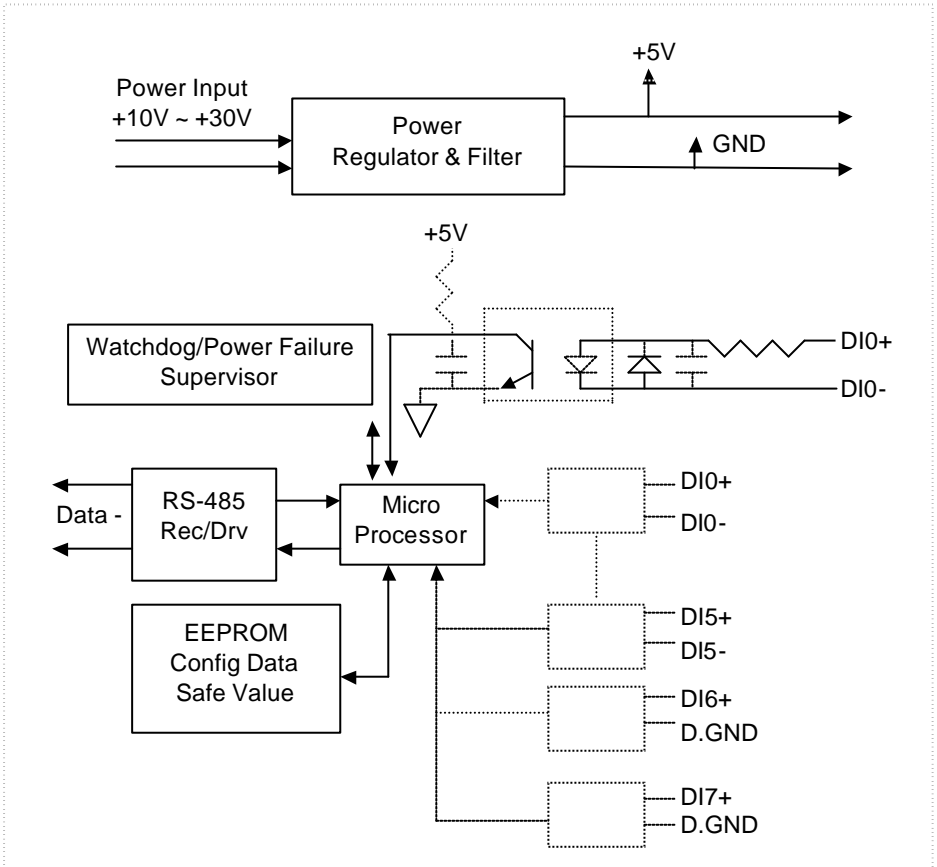

1.4 Overview of NuDAM-6053

1.4.1 What is NuDAM-6053 ?

NuDAM-6053 provides 16 digital input channels for dry contact or wet contact signals. The effective distance from DI to contact point is up to 500m for dry contact input.

1.4.2 Features of NuDAM-6053

- 16 bits digital input
- Programmable host watchdog timer for host failure protection
- Internal watchdog timer for device failure protection
- Easy programming by software
- Easy installation and wiring

1.4.3 Specifications of NuDAM-6053

◆ Interface

- Interface : RS-485, 2 wires
- Speed (bps) : 1200, 2400, 4800, 9600, 19.2K, 38.4K, 115.2K (115.2K only for firmware reversion above A4.00)

◆ Input

- Channel numbers : 16
- Dry Contact:
 - Logical level 0 : close to GND
 - Logical level 1 : open
- Wet Contact :
 - Logical level 0 : +2V max.
 - Logical level 1 : +4V ~ +30V

◆ Watchdog Function

- Module internal watchdog timer : 150ms

- Power failure threshold : 4.65 V
 - Host programmable watchdog : 100 ms ~ 25.5 sec
- ◆ **Power**
- Power supply : +10V to +30V
 - Current consumption : 0.4 W

1.4.4 A Look at ND-6053 & Pin Assignment

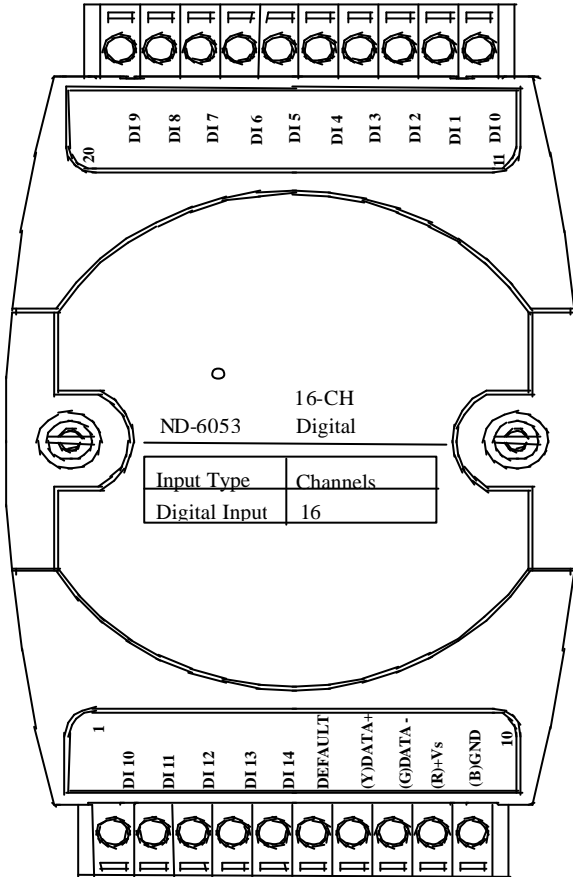

1.4.5 Pin Definitions of NuDAM-6053

| Pin # | Signal Name | Description |
|-------|-------------------|---|
| 1 | DI10 | Digital Input Channel 10 |
| 2 | DI11 | Digital Input Channel 11 |
| 3 | DI12 | Digital Input Channel 12 |
| 4 | DI13 | Digital Input Channel 13 |
| 5 | DI14 | Digital Input Channel 14 |
| 6 | Default* /DI15 | Initial state setting / Digital Input Channel 15 |
| 7 | (Y) DATA+ | RS-485 series signal, positive |
| 8 | (G) DATA- | RS-485 series signal, negative |
| 9 | (R) +VS | Power supply, +10V~+30V |
| 10 | (B) GND | Ground |
| 11 | DI0 | Digital Input Channel 0 |
| 12 | DI1 | Digital Input Channel 1 |
| 13 | DI2 | Digital Input Channel 2 |
| 14 | DI3 | Digital Input Channel 3 |
| 15 | DI4 | Digital Input Channel 4 |
| 16 | DI5 | Digital Input Channel 5 |
| 17 | DI6 | Digital Input Channel 6 |
| 18 | DI7 | Digital Input Channel 7 |
| 19 | DI8 | Digital Input Channel 8 |
| 20 | DI9 | Digital Input Channel 9 |

1.4.6 ND-6053 Functional Block Diagram

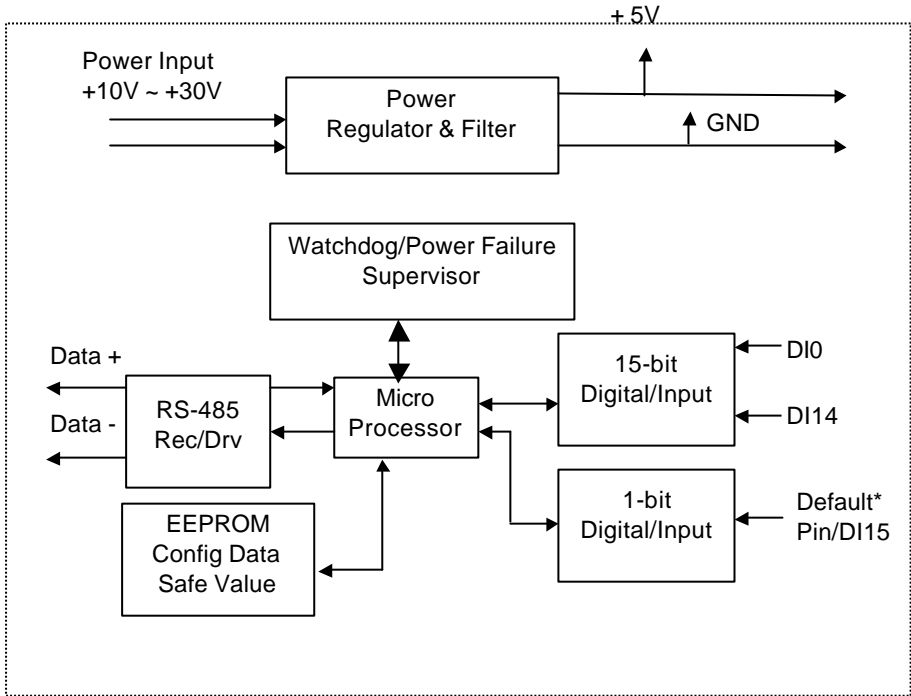

1.5 Overview of NuDAM-6054

1.5.1 What is NuDAM-6054 ?

NuDAM-6054 provides 15 isolated digital input channels. All of the input channels are common power type and one of them is using the same pin with default (use jumper to choose). The isolation voltage is up to 5000 Vrms. It is suitable to use NuDAM-6054 in industrial environment with the dangerous of high voltage electric shock.

1.5.2 Features of NuDAM-6054

- 15 bits digital inputs with isolation protection and common power
- 5000 Vrms isolation voltage
- Programmable host watchdog timer for host failure protection
- Internal watchdog timer for device failure protection
- Easy programming by software
- Easy installation and wiring

1.5.3 Specifications of NuDAM-6054

◆ Interface

- Interface : RS-485, 2 wires
- Speed (bps) : 1200, 2400, 4800, 9600, 19.2K, 38.4K, 115.2K (115.2K only for firmware reversion above A4.00)

◆ Input

- Channel numbers : 15 isolation common power input channels (the fifteenth channel is the same with default pin, but can use jumper to choose)
- Input type : source type
- Effective distance: 500 m
- Common external voltage: 24V

◆ Watchdog Function

- Module internal watchdog timer : 150msec
 - Power failure threshold : 4.65 V
 - Host programmable watchdog :100 ms ~ 25.5 sec
- ◆ **Power**
- Power supply : +10V to +30V
 - Power consumption : 0.4 W

1.5.4 A Look at ND-6054 & Pin Assignment

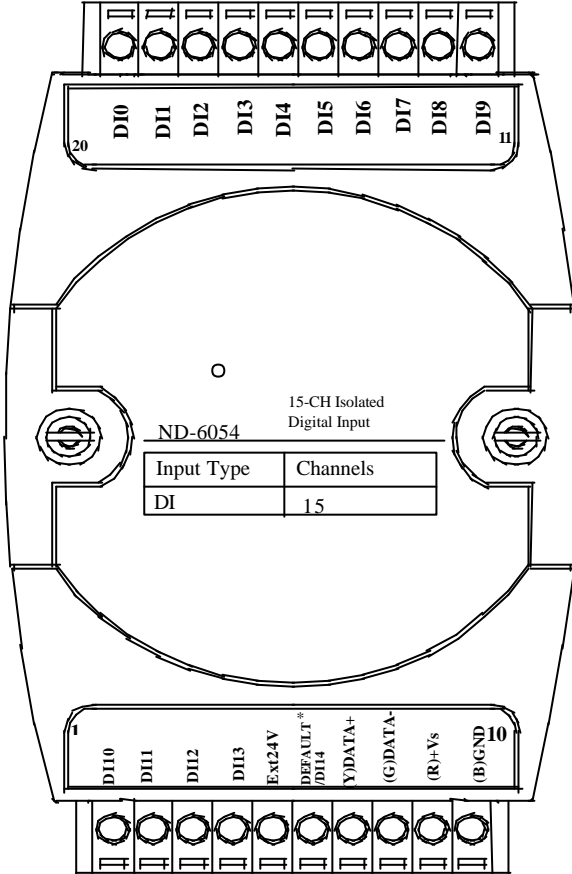

1.5.5 Pin Definitions of NuDAM-6054

| Pin # | Signal Name | Description |
|-------|---------------|---|
| 1 | DI10 | Digital input channel 10 |
| 2 | DI11 | Digital input channel 11 |
| 3 | DI12 | Digital input channel 12 |
| 4 | DI13 | Digital input channel 13 |
| 5 | Ext24V | External common +24V |
| 6 | Default*/DI14 | Initial state setting or digital input channel 14 |
| 7 | (Y) DATA+ | RS-485 series signal, positive |
| 8 | (G) DATA- | RS-485 series signal, negative |
| 9 | (R) +VS | Power supply, +10V~+30V |
| 10 | (B) GND | Ground |
| 11 | DI9 | Digital input channel 9 |
| 12 | DI8 | Digital input channel 8 |
| 13 | DI7 | Digital input channel 7 |
| 14 | DI6 | Digital input channel 6 |
| 15 | DI5 | Digital input channel 5 |
| 16 | DI4 | Digital input channel 4 |
| 17 | DI3 | Digital input channel 3 |
| 18 | DI2 | Digital input channel 2 |
| 19 | DI1 | Digital input channel 1 |
| 20 | DI0 | Digital input channel 0 |

1.5.6 ND-6054 Functional Block Diagram

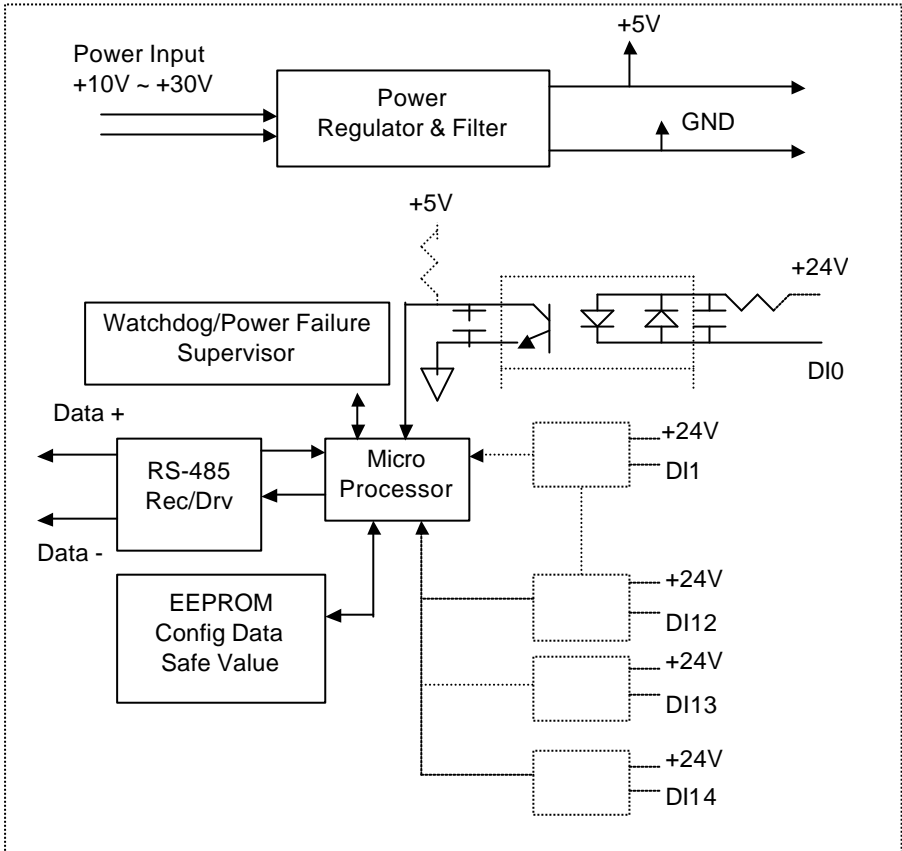

1.6 Overview of NuDAM-6056

1.6.1 What is NuDAM-6056 ?

NuDAM-6056 provides 15 isolated digital output channels. All of the output channels are common ground type and one of them is use the same pin with default (use jumper to choose). The isolation voltage is up to 5000 Vrms. It is suitable to use NuDAM-6056 in industrial environment with the dangerous of high voltage electric shock.

1.6.2 Features of NuDAM-6056

- ◆ 15 bits digital open collector output with isolation protection and common ground
- ◆ 5000 Vrms isolation voltage
- ◆ Programmable host watchdog timer for host failure protection
- ◆ Internal watchdog timer for device failure protection
- ◆ Easy programming by software
- ◆ Easy installation and wiring

1.6.3 Specifications of NuDAM-6056

◆ Interface

- Interface : RS-485, 2 wires
- Speed (bps) : 1200, 2400, 4800, 9600, 19.2K, 38.4K, 115.2K (115.2K only for firmware reversion above A4.00)

◆ Digital Output

- Channel numbers : 15 isolation common ground output channels(the fifteenth channel is the same with default pin,but could use jumper to choose).
- Output characteristic:open collector transistor
- Maximum current sink:50mA(300mA for Hardware Reversion.A2)
- Max.power dissiation:200mW(3W for Hardware Reversion.A2)
- Isolation Voltage:5000Vrms

◆ **Watchdog Function**

- Module internal watchdog timer : 150msec
- Power failure threshold : 4.65 V
- Safe value : 15 output channels
- Host programmable watchdog :100 ms ~ 25.5 sec

◆ **Power**

- Power supply : +10V to +30V
- Current consumption : 0.3 W(Max 3.5W for Hardware Reversion.A2)

1.6.4 A Look at ND-6056 & Pin Assignment

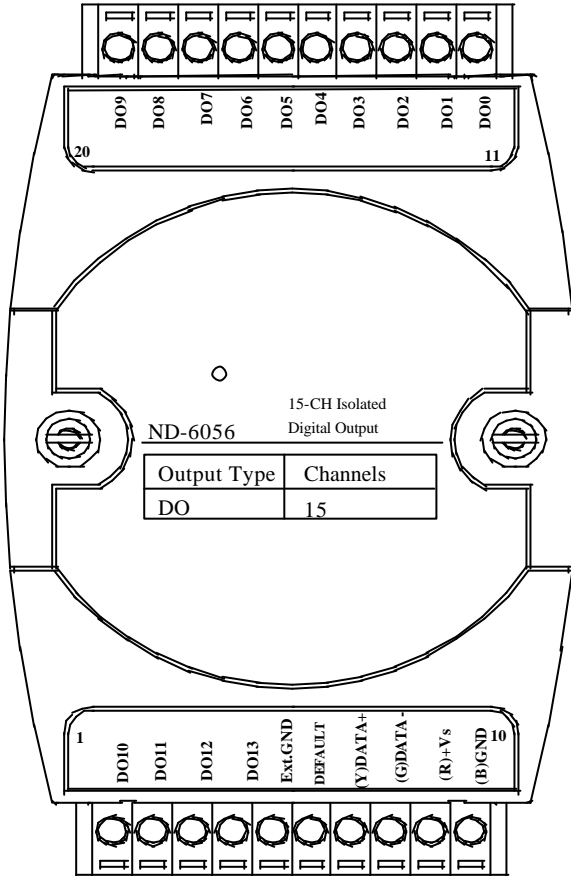

1.6.5 Pin Definitions of NuDAM-6056

| Pin # | Signal Name | Description |
|-------|-------------------|--|
| 1 | DO10 | Digital output channel 10 |
| 2 | DO11 | Digital output channel 11 |
| 3 | DO12 | Digital output channel 12 |
| 4 | DO13 | Digital output channel 13 |
| 5 | ExtGND | |
| 6 | Default*/ DO14 | Initial state setting Digital output channel 14 |
| 7 | (Y) DATA+ | RS-485 series signal, positive |
| 8 | (G) DATA- | RS-485 series signal, negative |
| 9 | (R) +VS | Power supply, +10V~+30V |
| 10 | (B) GND | Ground |
| 11 | DO0 | Digital output channel 0 |
| 12 | DO1 | Digital output channel 1 |
| 13 | DO2 | Digital output channel 2 |
| 14 | DO3 | Digital output channel 3 |
| 15 | DO4 | Digital output channel 4 |
| 16 | DO5 | Digital output channel 5 |
| 17 | DO6 | Digital output channel 6 |
| 18 | DO7 | Digital output channel 7 |
| 19 | DO8 | Digital output channel 8 |
| 20 | DO9 | Digital output channel 9 |

1.6.6 ND-6056 Functional Block Diagram

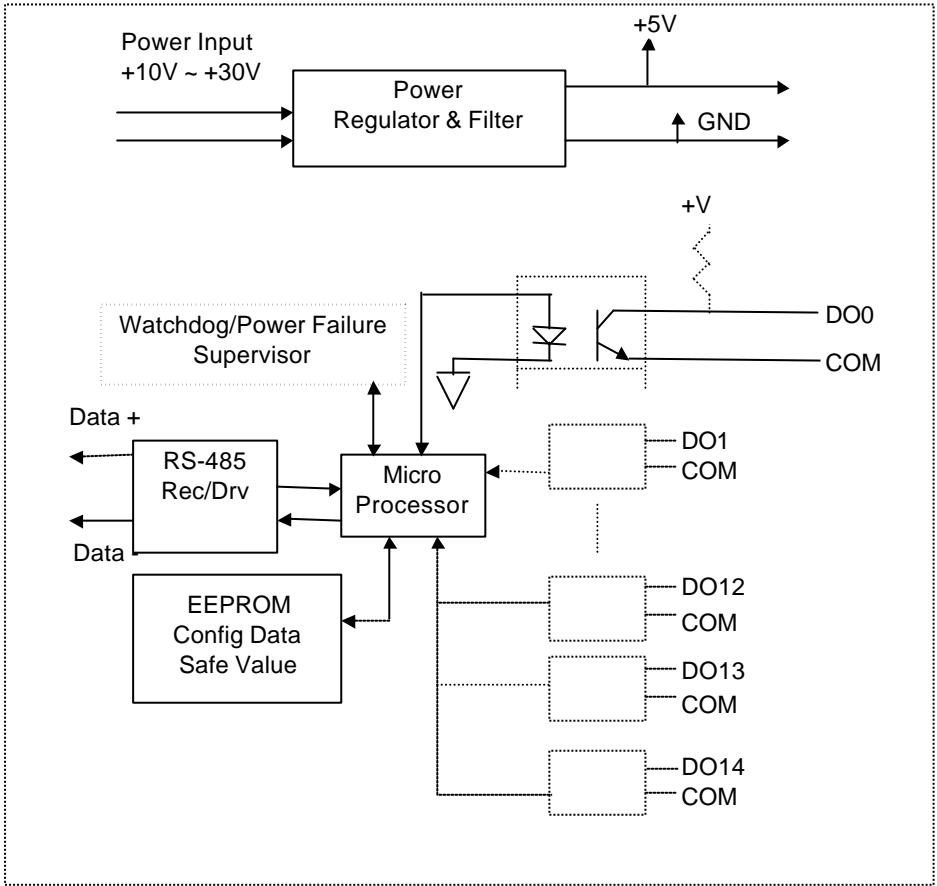

1.7 Overview of NuDAM-6058

1.7.1 What is NuDAM-6058 ?

NuDAM-6058 provides 28 digital I/O channels. It emulates industry standard mode zero configuration of 8255 programmable peripheral interface (PPI) chip. The PPI offers 3 ports A, B and C, the C port can also be subdivided into 2 nibble-wide (4-bit) port – C upper and C lower. A 50 pin SCSI connector equipped with ND-6058 which is corresponding to PPI chip with 24 DIO points.

1.7.2 Features of NuDAM-6058

- ◆ Industry standard 8255 programmable peripheral interface mode 0 emulation
- ◆ 24 Programmable I/O channels
- ◆ 4 dedicated input channels
- ◆ Completely TTL compatible I/O lines
- ◆ Status read-back capability
- ◆ Direct bit set/reset capability
- ◆ Buffered circuits for higher driving capability
- ◆ Direct interface with OPTO-22 compatible I/O module
- ◆ Programmable host watchdog timer for host failure protection
- ◆ Internal watchdog timer for device failure protection
- ◆ On board resettable fuse to protect power supply form external devices
- ◆ Easy programming by software
- ◆ Easy installation and wiring

1.7.3 Specifications of NuDAM-6058

◆ Interface

- Interface : RS-485, 2 wires
- Speed (bps) : 1200, 2400, 4800, 9600, 19.2K, 38.4K, 115.2K (115.2K only for firmware reversion above A4.00)

◆ Programmable Digital Input/Output

- Channel numbers : 24
- Input Signal:
 - Logical level 0 : -0.5 ~ 0.8 V
 - Logical level 1: 2.0 ~ 5.25 V
- Output Signal:
 - Logical level 0: 0.5 V Maximum
 - Logical level 1: 2.4 V Minimum Digital Output

◆ Watchdog Function

- Module internal watchdog timer : 150msec
- Power failure threshold : 4.65 V
- Safe value : 15 output channels
- Host programmable watchdog : 100 ms ~ 25.5 sec

◆ Dedicated Digital Input

- Channel numbers : 4
- Input Signal:
 - Logical level 0: 2 V max.
 - Logical level 1: 3 V ~ 5.25 V

◆ Connector

- 10-pin skew terminal block

- 50-pin SCSI II connector
- ◆ **Power**
 - Power supply : +10V to +30V
 - Current consumption: 1.7 W

1.7.4 A Look at ND-6058 & Pin Assignment

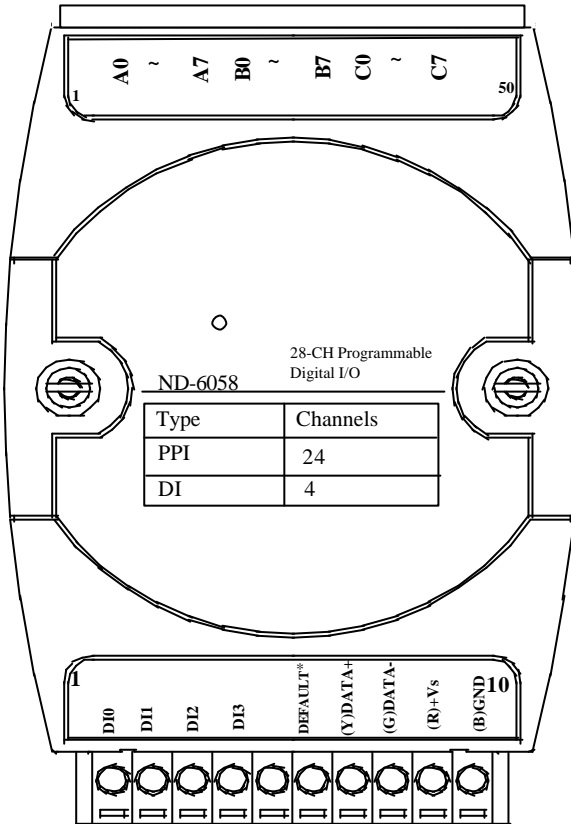

1.7.5 Pin Definitions of NuDAM-6058

| Pin # | Signal Name | Description |
|-------|-------------|--------------------------------|
| 1 | DI0 | Digital input channel 0 |
| 2 | DI1 | Digital input channel 1 |
| 3 | DI2 | Digital input channel 2 |
| 4 | DI3 | Digital input channel 3 |
| 5 | | |
| 6 | Default* | Initial state setting |
| 7 | (Y) DATA+ | RS-485 series signal, positive |
| 8 | (G) DATA- | RS-485 series signal, negative |
| 9 | (R) +VS | Power supply, +10V~+30V |
| 10 | (B) GND | Ground |

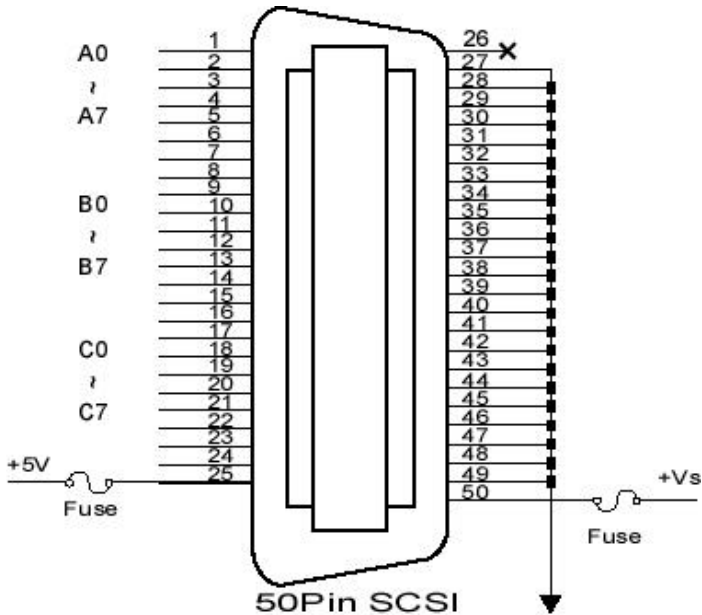

1.7.6 ND-6058 Functional Block Diagram

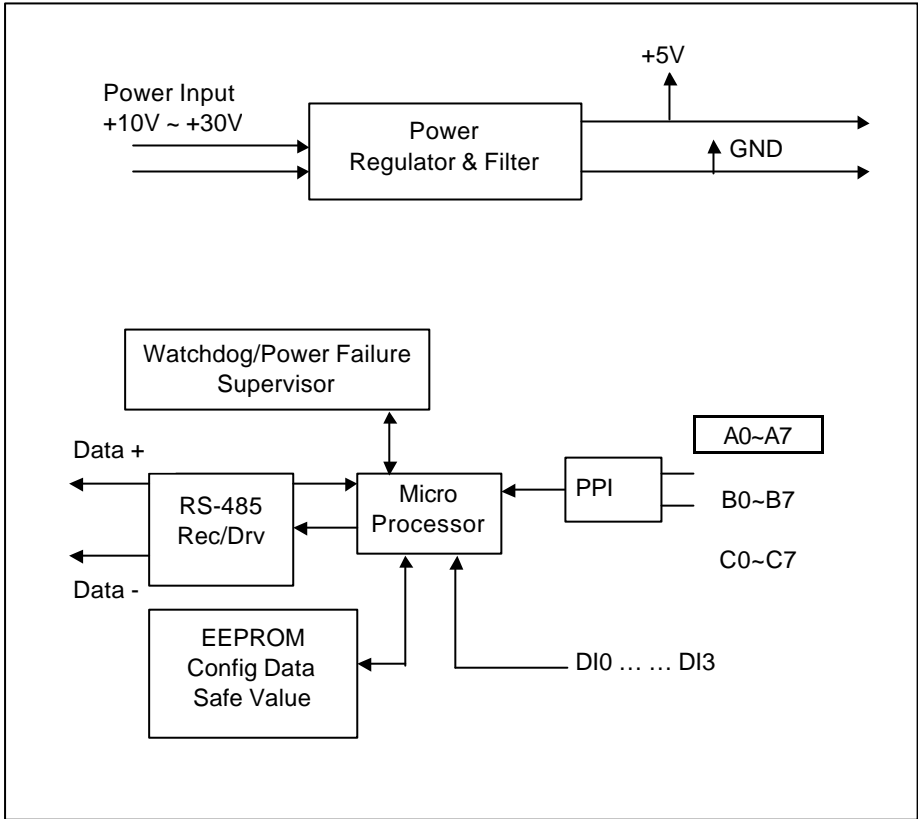

1.8 Overview of NuDAM-6060

1.8.1 What is NuDAM-6060 ?

NuDAM-6060 provides four relay output channels, two are form A and two are form C. It can control high power devices without external circuits. The isolation guarantees the industrial safety.

1.8.2 Features of NuDAM-6060

- ◆ 4 channels relay output
- ◆ 4 channels isolated digital input
- ◆ Programmable host watchdog timer for host failure protection
- ◆ Internal watchdog timer for device failure protection
- ◆ Easy programming by software
- ◆ Easy installation and wiring

1.8.3 Specifications of NuDAM-6060

- ◆ **Interface**
 - Interface : RS-485, 2 wires
 - Speed (bps) : 1200, 2400, 4800, 9600, 19.2K, 38.4K, 115.2K (115.2K only for firmware reversion above A4.00)
- ◆ **Input**
 - Channel numbers : 4
 - Common External Voltage : +24 V
 - Input Type : Source Type
- ◆ **Output**
 - Channel numbers : 4 relay output
 - Output type : 2 form C channels, 2 form A channels
 - Contact rating : AC 0.6A /125 V, 0.3A / 250V

- DC 2A / 30V, 0.6A / 110V
- Relay ON/OFF time interval : 3 ms / 1ms
- Breakdown voltage : 500 V
- Expected life : 10^8 times
- Insulation resistance : 1000 M Ω minimum

- ◆ **Watchdog Function**
 - Module internal watchdog timer : 150ms
 - Power failure threshold : 4.65 V
 - Safety value : 4 output channels
 - Host programmable watchdog : 100 ms ~ 25.5 sec

- ◆ **Power**
 - Power supply : +10V to +30V
 - Current consumption : 0.8 W

1.8.4 Using Relay Output

The ND-6060 contains two types of relay : Form C and Form A. The relay R3 and R4 are form C relays, and R1 and R2 are plain form A type. The difference between these two types of relay are:

1. Form C Relay : (R3, R4)

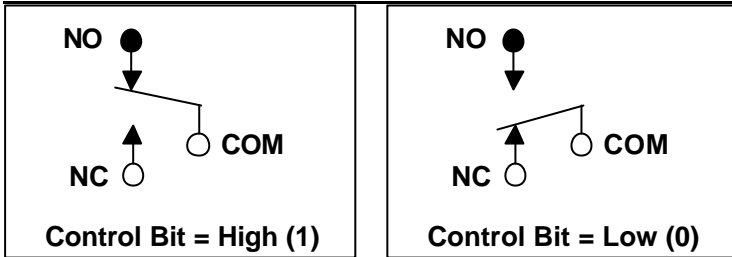

Form C relay has three contacts : NC (Normal Close), NO (Normal Open), and COM(Common). The COM post, located at the middle, can make contact either NO post or NC post. When the control bit is high (1), the COM post and NO post are contacted. If the control bit is low (0), the COM post and NC post make contact.

In normal power-up and reset, the relay is in **low** status.

2. Form A Relay : (R1, R2)

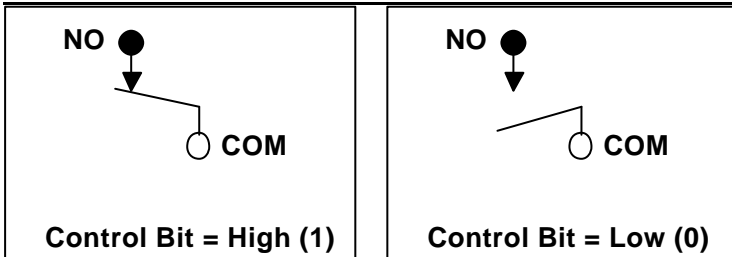

Form A relay only has two contacts : NO (Normal Open) and COM(Common). The COM post can make contact either NO post or not contact NO post. When the control bit is high (1), the COM post and NO post are contacted. If the control bit is low (0), the COM post and NO post does not make contact. In normal power-up and reset, the relay is in **low** status.

1.8.5 A Look at ND-6060 & Pin Assignment

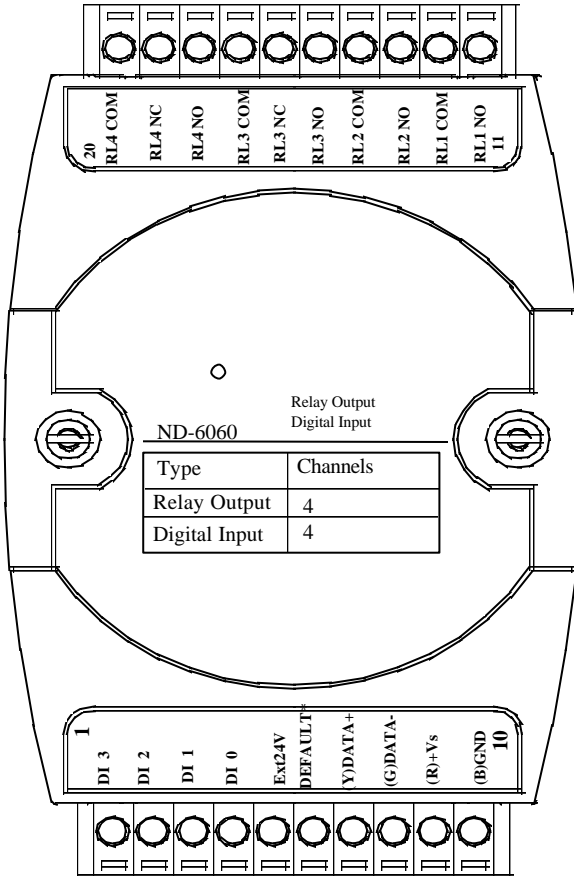

1.8.6 Pin Definitions of NuDAM-6060

| Pin # | Signal Name | Description |
|-------|-------------|--------------------------------|
| 1 | DI3 | Digital Input Channel 3 |
| 2 | DI2 | Digital Input Channel 2 |
| 3 | DI1 | Digital Input Channel 1 |
| 4 | DI0 | Digital Input Channel 0 |
| 5 | Ext24 | External Common +24V |
| 6 | Default* | Initial state setting |
| 7 | (Y) DATA+ | RS-485 series signal, positive |
| 8 | (G) DATA- | RS-485 series signal, negative |
| 9 | (R) +VS | Power supply, +10V~+30V |
| 10 | (B) GND | Ground |
| 11 | RL1 NO | Relay 1, normal open |
| 12 | RL1 COM | Relay 1, common ground |
| 13 | RL2 NO | Relay 2, normal open |
| 14 | RL2 COM | Relay 2, common ground |
| 15 | RL3 NO | Relay 3, normal open |
| 16 | RL3 NC | Relay 3, normal close |
| 17 | RL3 COM | Relay 3, common ground |
| 18 | RL4 NO | Relay 4, normal open |
| 19 | RL4 NC | Relay 4, normal close |
| 20 | RL4 COM | Relay 4, common ground |

1.8.7 ND-6060 Functional Block Diagram

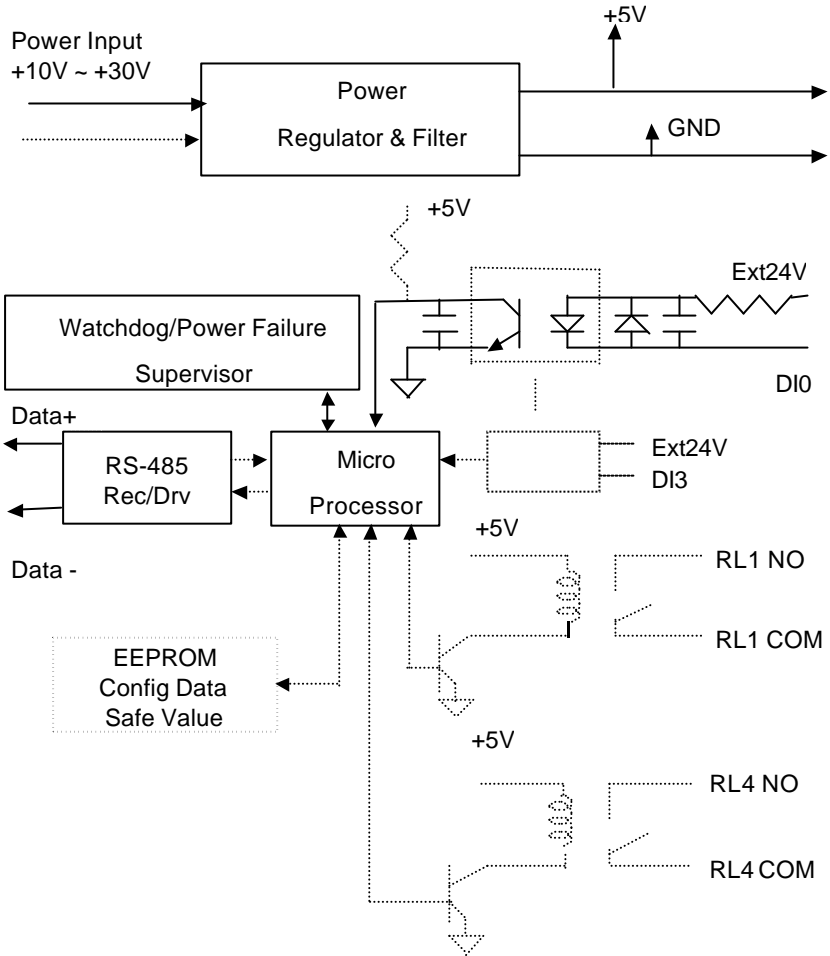

1.9 Overview of NuDAM-6063

1.9.1 What is NuDAM-6063 ?

NuDAM-6063 provides eight form A relay output channels. It can control high power devices without external circuits.

1.9.2 Features of NuDAM-6063

- ◆ 8 channel relay output
- ◆ Programmable host watchdog timer for host failure protection
- ◆ Internal watchdog timer for device failure protection
- ◆ Easy programming by software
- ◆ Easy installation and wiring

1.9.3 Specifications of NuDAM-6063

- ◆ **Interface**
 - Interface : RS-485, 2 wires
 - Speed (bps) : 1200, 2400, 4800, 9600, 19.2K, 38.4K, 115.2K (115.2K only for firmware reversion above A4.00)
- ◆ **Digital Output**
 - Channel numbers : 8
 - Output Type : 8 form A channels
 - Contact rating : AC 0.5A / 125V
 - DC 1A / 30V
 - Relay ON/OFF time interval : 3ms / 3ms
 - Breakdown voltage : 1000Vrms
 - Expected life : 10^7
- ◆ **Insulation Resistance: 1,000 MW**

◆ **Watchdog Function**

- Module internal watchdog timer : 150ms
- Power failure threshold : 4.65 V
- Safety value : 8 output channels
- Host programmable watchdog : 100 ms ~ 25.5 sec

◆ **Power**

- Power supply : +10V to +30V
- Current consumption : 1.2 W

1.9.4 Using Relay Output

Form A Relay :

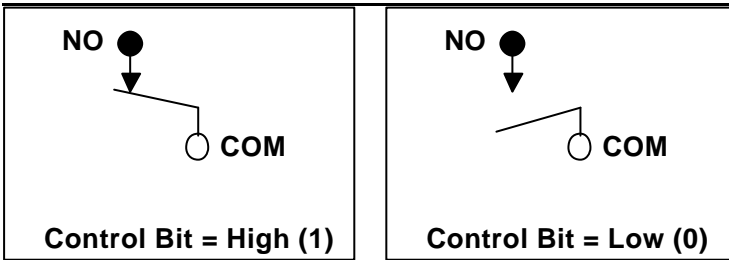

Form A relay only has two contacts : NO (Normal Open) and COM(Common). The COM post can make contact either NO post or not contact NO post. When the control bit is high (1), the COM post and NO post are contacted. If the control bit is low (0), the COM post and NO post does not make contact.

In normal power-up and reset, the relay is in **low** status.

1.9.5 A Look at ND-6063 & Pin Assignment

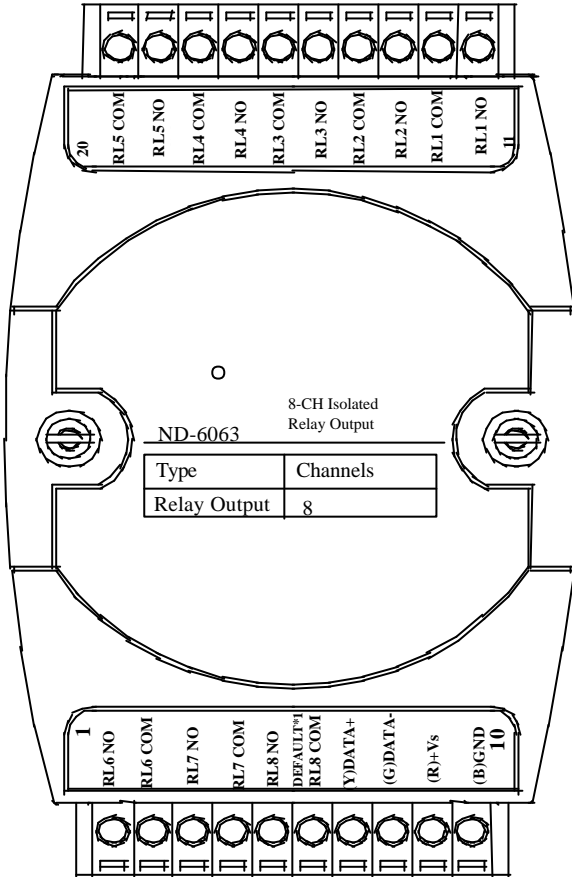

1.9.6 Pin Definitions of NuDAM-6063

| Pin # | Signal Name | Description |
|-------|------------------|---|
| 1 | RL6 NO | Relay 6, normal open |
| 2 | RL6 COM | Relay 6, common ground |
| 3 | RL7 NO | Relay 7, normal open |
| 4 | RL7 COM | Relay 7, common ground |
| 5 | RL8 NO | Relay 8, normal open |
| 6 | Default*/ RL8 NO | Initial state setting Relay 8, normal open |
| 7 | (Y) DATA+ | RS-485 series signal, positive |
| 8 | (G) DATA- | RS-485 series signal, negative |
| 9 | (R) +VS | Power supply, +10V~+30V |
| 10 | (B) GND | Ground |
| 11 | RL1 NO | Relay 1, normal open |
| 12 | RL1 COM | Relay 1, common ground |
| 13 | RL2 NO | Relay 2, normal open |
| 14 | RL2 COM | Relay 2, common ground |
| 15 | RL3 NO | Relay 3, normal open |
| 16 | RL3 COM | Relay 3, common ground |
| 17 | RL4 NO | Relay 4, normal open |
| 18 | RL4 COM | Relay 4, common ground |
| 19 | RL5 NO | Relay 5, normal open |
| 20 | RL5 COM | Relay 5, common ground |

1.9.7 ND-6063 Functional Block Diagram

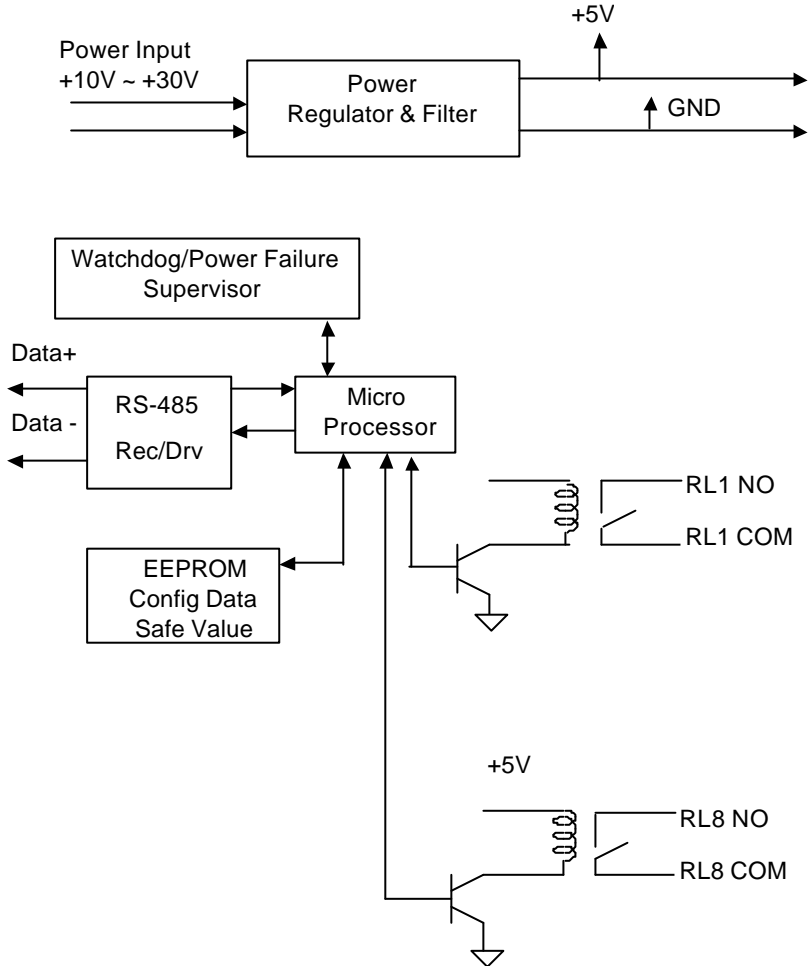

2

Initialization & Installation

2.1 Software Installation

1. If you have already installed “NuDAM Administration” then skip other steps.
2. Backup your software diskette.
3. Insert “NuDAM Administration” disc into CD-ROM.
4. Change drive to the path of CD-ROM. For example, your drive of CD-ROM is F:, then change the drive to F:
5. Find the setup of NuDAM Administration and run it.
6. Please follow the steps of setup program then you can successful to install the nudism Administration.

2.2 Initializing a Brand-New Module

2.2.1 Objective of Initializing a Brand-New NuDAM

All NuDAM modules, except NuDAM-6520 and NuDAM-6510, in a RS-485 network must have an *unique* address ID, however, every brand-new NuDAM has a factory default setting as following :

- ◆ Address ID is 01.
- ◆ Baud rate is 9600 bps
- ◆ Check-sum disable
- ◆ Host Watchdog timer is disable

Therefore, to configure the brand-new NuDAM before using is necessary, otherwise the address ID will be conflict with others modules because the ID of new modules are identity . The baud rate may also be changed according to user's requirements.

The following sections show how to initialize a brand-new module, which is applicable for initializing NuDAM-6050, NuDAM-6052, NuDAM-6053, NuDAM-6054, NuDAM-6056, NuDAM-6058, NuDAM-6060, and NuDAM-6063.

2.2.2 Default State

The NuDAM I/O modules must be set at *Default State* when you want to change the default settings, such as the ID address, baud rate, check-sum status etc. All NuDAM I/O modules have an special pin labeled as **DEFAULT***. The module will be in *Default State* if the **DEFAULT*** pin is shorted to ground when power ON. Under this state, the default configuration is set as following :

- ◆ Address ID is 00
- ◆ Baud rate is 9600 bps
- ◆ Check-sum disable

Therefore, the communication between host and the module will can be easily set as the same configuration, the initialization of a module will be possible no matter what configuration is set under operating state.

For ND-6053, ND-6054 and ND-6056, the pin 6 is used for both DI15(DO15) and **DEFAULT***, and also the ND-6063, the pin 6 is used for both RL8 COM and **DEFAULT***. The jumper setting is as below, and the default setting is DI15(DO15) or RL8 COM. When you want to use ND-6053, ND-6054, ND-6056 or ND-6063 as **Default***, you should open the module case to set the JP2.

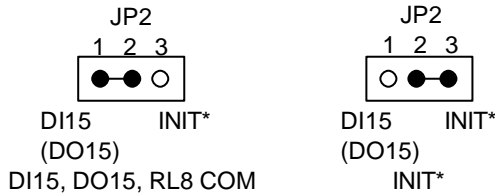

2.2.3 Initialization Equipments

- ◆ Host computer with an RS-232 port
- ◆ An installed RS-485 module (NuDAM-6520) with 9600 baud rate
- ◆ The brand new NuDAM module
- ◆ Power supply (+10 to +30 V_{DC}) for NuDAM modules
- ◆ Administration utility software

Note1: Never Connect the DRFAULT* pin to Vs or power source just left it open or wired to GND.

2.2.4 Initialization Procedure

1. Power off the host computer and the installed NuDAM-6520. Be sure of the baud rate of the NuDAM-6520 is 9600 bps.
2. Connect a brand new NuDAM module with the RS-485. Set the module in *Default State* by shorting the **DEFAULT*** pin. Refer to Figure 2.1 for detailed wiring.
3. Power on the host computer.
4. Power on the power supply for NuDAM modules.
5. Use the NuDAM Administrating utility to configure the address ID, Baud rate and check-sum status of the module.

2.2.5 Initialization Wiring

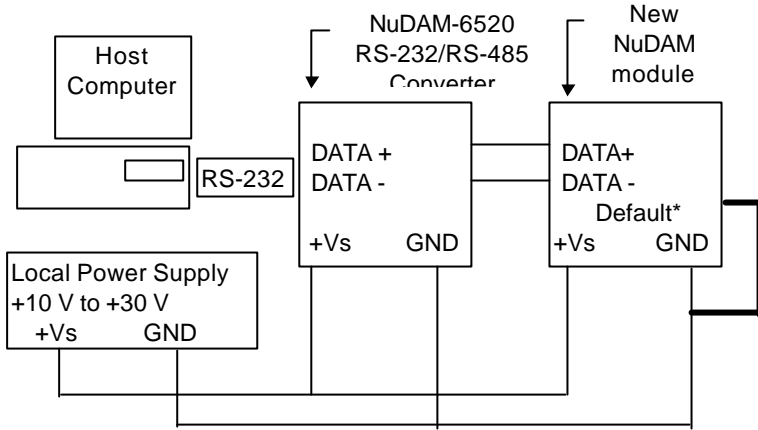

Figure 2-1 Layout for Configuring the NuDAM module

2.3 Install a New NuDAM to a Existing Network

2.3.1 Equipments for Install a New Module

- ◆ A existing NuDAM network
- ◆ New NuDAM modules.
- ◆ Power supply (+10 to +30 V_{DC})

2.3.2 Installing Procedures

1. Configure the new NuDAM module according to the initialization procedure in section 2.2.
2. The baud rate and check-sum status of the new module must be identity with the existing RS-485 network. The address ID must not be conflict with other NuDAM modules on the network.
3. Power off the NuDAM power supply of the existing RS-485 network.
4. Power off the host computer.
5. Wire the power lines for the new NuDAM with the existing network. Be careful about the signal polarity as wiring.
6. Wire the RS-485 data lines for the new NuDAM with the existing network. Be careful about the signal polarity as wiring.
7. Wire to the input or output devices. Refer to section 2.4 for illustrations.
8. Power on the host computer.
9. Power on the NuDAM local power supply.
10. Use the NuDAM administration utility to check entire network.

2.4 Application Wiring for NuDAM-6050

Digital Input Connect with TTL Signal

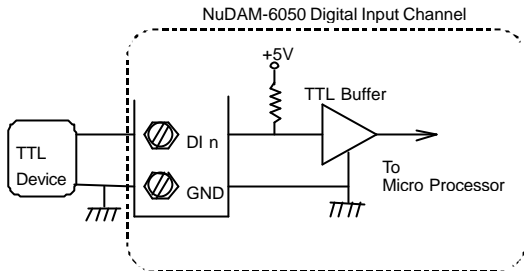

Digital Input Connect with Switch or Push Button

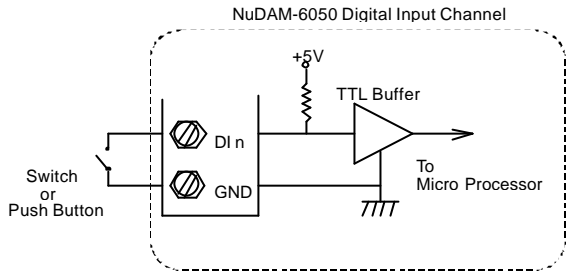

Digital Output Connect with Power Loading

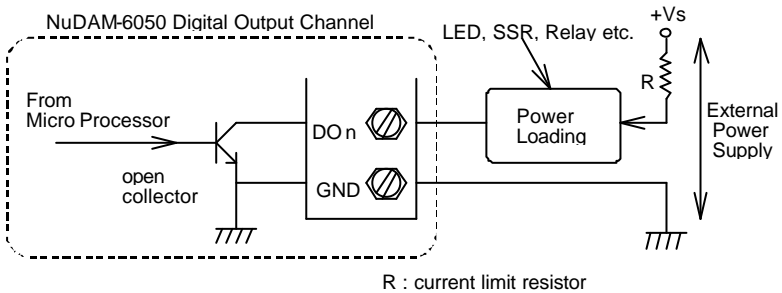

2.5 Application Wiring for NuDAM-6052

Isolated Differential Input

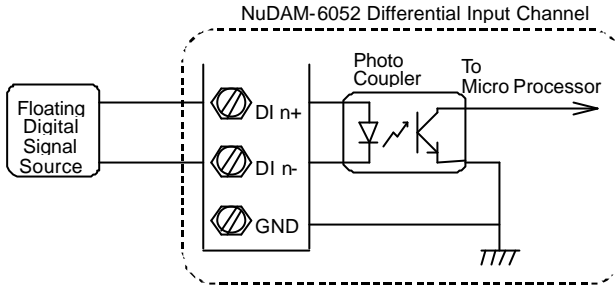

Isolated Single Ended Input

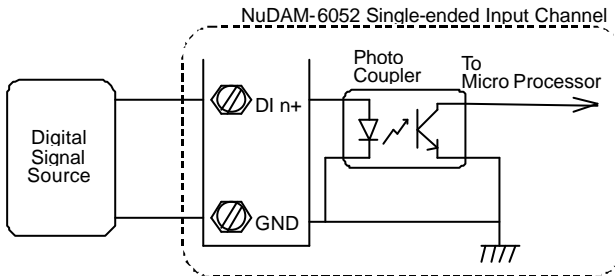

2.6 Application Wiring for NuDAM-6053

Wet Contact Input

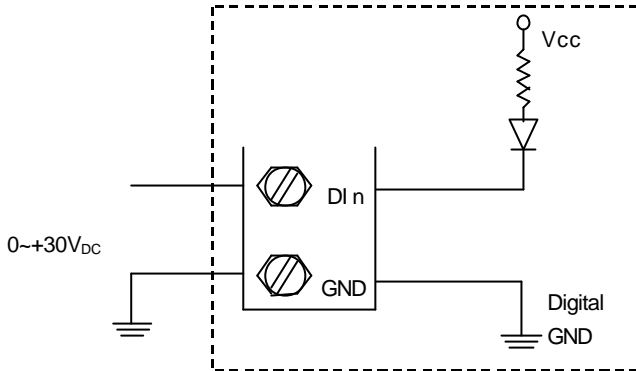

Contact Closure Input

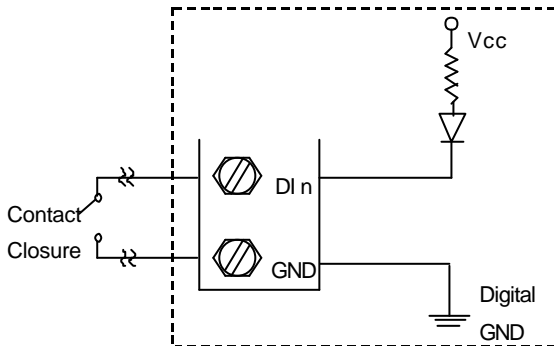

2.7 Application Wiring for NuDAM-6054

Isolated Common Power Input

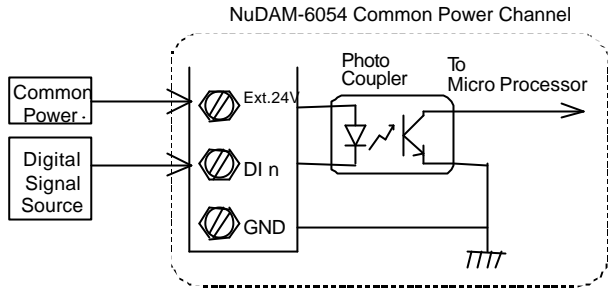

2.8 Application Wiring for NuDAM-6056

Isolated Common Ground Output

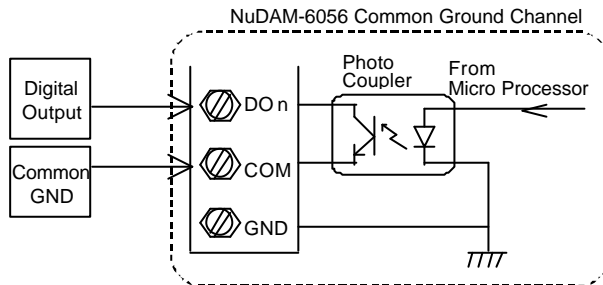

2.9 Application Wiring for NuDAM-6058

Digital Input Connect with TTL Signal

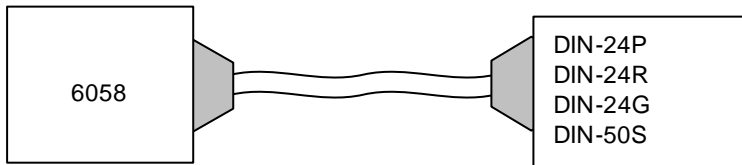
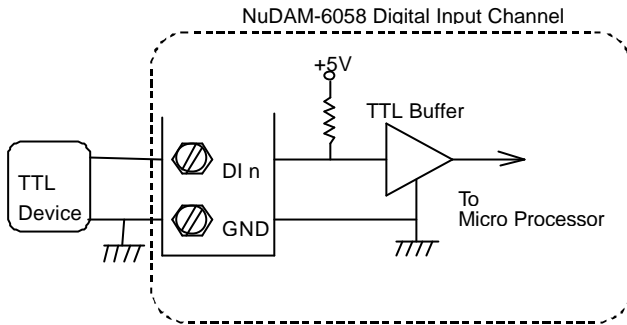

DIN-24P

24-CH Opt-Isolated Digital Input Termination Board with DIN Socket.

DIN-24R

24-CH Relay Output Termination Board with DIN Socket.

DIN-24G

24-CH Grayhill I/O Modules Termination Board with DIN Socket.

DIN-50S

50-Pin SCSI Connector Termination Board with DIN Socket.

2.10 Application Wiring for NuDAM-6060

Form C Relay Output

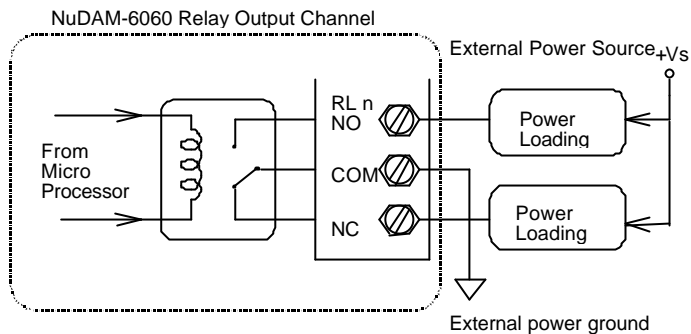

Form A Relay Output

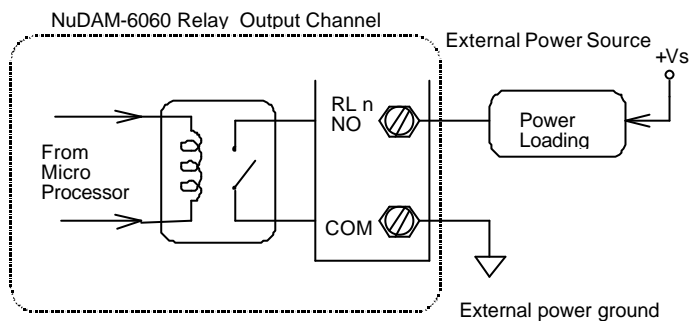

Digital Input : Contact Mode

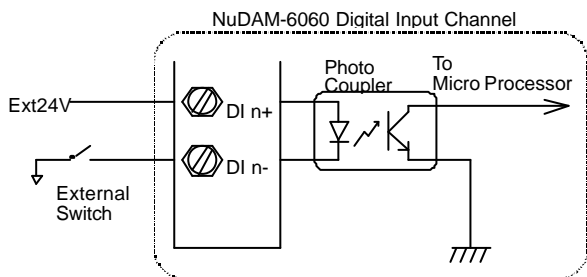

Digital Input : Transistor Mode

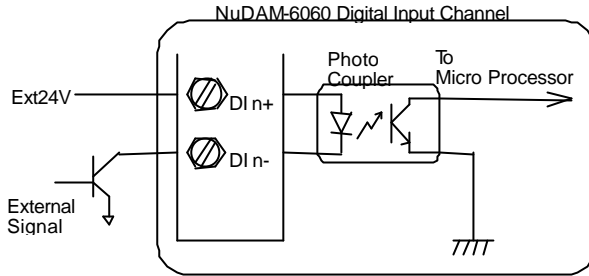

2.11 Application Wiring for NuDAM-6063

Form A Relay Output

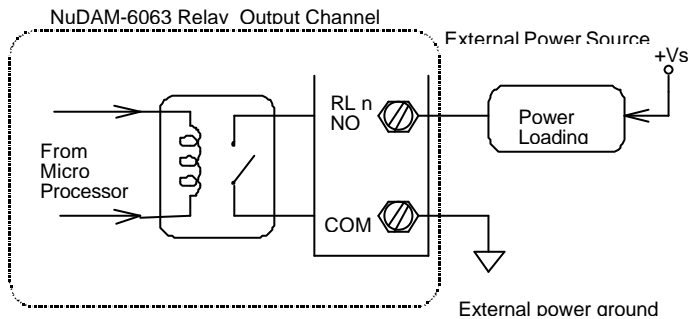

3

Command Set

3.1 Command and Response

3.1.1 Introduction

The NuDAM command is composed by numbers of characteristics, including the leading code, address ID, the variables, the optional check-sum byte, and a carriage return to indicate the end of a command. The host computer can only command only one NuDAM module except those synchronized commands with wildcard address "***". The NuDAM may or may not give response to the command. The host should check the response to handshake with the modules.

3.1.2 Document Conventions

The following syntax conventions are used to describe the NuDAM commands in this manual.

| | |
|--------------------|---|
| (Leading Code) | Leading Code is the first characteristic of the NuDAM command. All NuDAM commands need a command leading code, such as %,\$,#,@,...etc. 1- character |
| (Addr) | Module's address ID, the value is in the range of 00 - FF (Hexadecimal) if no specified in the following 2- character |
| (Command Variable) | Items indicate command codes or value of variables Variable length |
| [Data] | Some output command need data Variable length |
| [Checksum] | Checksum in brackets indicate optional parameter, only checksum is enable then this field is required 2- character |
| <> | Identifies a control code character, such as <CR> for carriage return, its value is 0x0D. 1- character |

3.1.3 Format of NuDAM Commands

```
[(Leading Code)(Addr)(Command)[Data][Checksum]<CR>]
```

When checksum is enable then **[Checksum]** is needed, it is 2-character.

How to calculate checksum value ?

[Checksum] = ((LeadingCode)+(Addr)+(Command)+[Data]) MOD 0x100

Example 1: checksum is **disable**

```
User Command: $012<CR>
Response: !01400600<CR>
```

```
$ : LeadingCode
01 : Address
2 : Command (Read Configuration)
<CR> : Carriage return 0x0D
```

Example 2: checksum is **enable**

```
User Command: $012B7<CR>
Response: !01400600AC<CR>
```

\$: LeadingCode
01 : Address
2 : Command (Read Configuration)
B7 : Checksum value
<CR> : Carriage return 0x0D

'\$' = 0x24 '0' = 0x30 '1' = 0x31 '2' = 0x30

B7 = (0x24 + 0x30 + 0x31 + 0x32) MOD 0x100

'!' = 0x24 '0' = 0x30 '1' = 0x31 '4' = 0x34
'6' = 0x36

**AC = (0x24 + 0x30 + 0x31 + 0x34 + 0x30 + 0x30 + 0x36 + 0x30
+ 0x30) MOD 0x100**

-
- Note :** 1. There is no spacing between characters.
2. At end of command need a <CR> carriage return 0x0D.
3. Checksum is optional parameter.
-

3.1.4 Response of NuDAM Commands

The response message depends on NuDAM command. The response is also composed with several characteristics, including leading code, variables, and carriage return for ending. There are two kinds of leading code for response message, "!" or ">" means valid command and "?" means invalid. By checking the response message, user can monitor the command is valid or invalid.

Note : Under the following conditions, there will have **no response** message.

1. The specified address ID is not exist.
 2. Syntax error.
 3. Communication error
 4. Some special commands does not have response.
-

3.2 Summary of Command Set

There are three categories of NuDAM commands. One is the general commands, including set configuration command, read configuration, reset, read module's name or firmware version, etc. Every NuDAM can response to the general commands.

The second category is the functional commands, which depends on functions of each module, not every module can execute all functions.

The third category is the special commands, including functions about the programmable watchdog timer, safe values, and the programmable leading code.

| Command Set of Digital I/O Modules | | |
|---|---|--|
| Command | Syntax | Module |
| General Commands | | |
| Set Configuration | %(OldAddr)(NewAddr) (TypeCode)(BaudRate) (ChecksumFlag) | ALL |
| Read Configuration | \$(Addr)2 | ALL |
| Read Module Name | \$(Addr)M | ALL |
| Read Firmware Version | \$(Addr)F | ALL |
| Reset Status | \$(Addr)5 | ALL |
| Functional Commands | | |
| Synchronized Sampling | *** | 6050, 6052, 6053, 6054, 6058, 6060 |
| Read Synchronized Data | \$(Addr)4 | 6050, 6052, 6053, 6054, 6058, 6060 |
| Digital Output | \$(Addr)(ChannelNo) (OutData) | 6050, 6060, 6063 |
| | \$(Addr)(Port)(Odata) | 6056, 6058 |
| | \$(Addr)(Port)(ChannelNo) (BitData) | 6056, 6058 |
| | \$(Addr)T(OdataA)(OdataB) (OdataC) | 6058 |
| Digital Input | \$(Addr)6 | ALL |
| Set Programmable I/O Mode | \$(Addr)S(IOSts) | 6058 |
| Special Commands | | |
| Read Command Leading Code Setting | ~(Addr)0 | ALL |
| Change Command Leading Code Setting | ~(Addr)10(C1)(C2)(C3) (C4)(C5)(C6) | ALL |
| Set Host Watchdog / Safety Value | ~(Addr)2(Flag)(TimeOut) (SafeValue) | ALL |
| Read Host WatchDog / Safe Value | ~(Addr)3 | ALL |
| Change Polarity | ~(Addr)CP(Status) | ALL |
| Read Polarity | ~(Addr)CR | ALL |
| Host is OK | ~** | ALL |

3.3 Set Configuration

(6050, 6052, 6053, 6054,
6056, 6058, 6060, 6063)

@Description

Configure the basic setting about address ID, baud rate, and checksum.

@Syntax

%(OldAddr)(NewAddr)(TypeCode)(BaudRate)(CheckSumFlag)<CR>

| | |
|----------------|--|
| % | Command leading code. (1-character) |
| (OldAddr) | NuDAM module original address ID. The default address ID of a brand new module is 01. The value range of address ID is 00 to FF in hexadecimal. (2-character) |
| (NewAddr) | New address ID, if you don't want to change address ID, let new address ID equals to the old one. (2-character) |
| (TypeCode) | Type Code is fixed <i>40H</i> for Digital I/O modules. (2-character) |
| (BaudRate) | Communication baud rate, refer to Table 3-1 for details. (2-character) |
| (CheckSumFlag) | Define check-sum status, refer to Table 3-2 for details. (2-character) |

@Response

!(Addr)<CR>

or

?(Addr)<CR>

| | |
|--------|---|
| (Addr) | Address ID. |
| ! | Command is valid. |
| ? | Command is invalid. Invalid parameter values, When you wanted to change the setting without grounding the DEFAULT* pin. |

Note : When you want to change the checksum or baud rate then the DEFAULT* pin should be grounded at first.

@Example

User command: %0130400600<CR>
 Response: !30<CR>

| Item | Meaning | Description |
|------|-----------------|--------------------------------------|
| % | (Leading Code) | Command leading code. |
| 01 | (OldAddr) | Original address ID is 01H. |
| 30 | (NewAddr) | New address ID is 30H (Hexadecimal). |
| 40 | (TypeCode) | Digital I/O module. |
| 06 | (BaudRate) | Baud rate is 9600. |
| 00 | (CheckSumFlag) | 00 means checksum is disable. |
| <CR> | Carriage return | 0x0D. |

| Code | Baudrate |
|------|------------|
| 03 | 1200 bps |
| 04 | 2400 bps |
| 05 | 4800 bps |
| 06 | 9600 bps |
| 07 | 19200 bps |
| 08 | 38400 bps |
| 09 | 115200 bps |

Table 0-1 Baud rate setting code

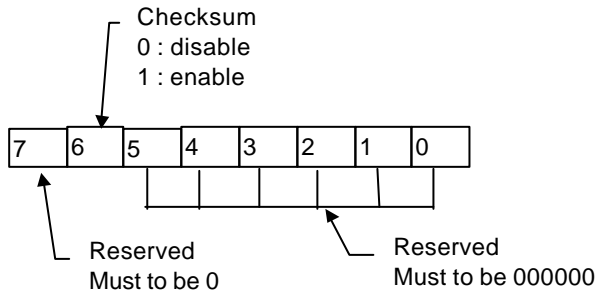

Table 0-2 Check sum flag setting

3.4 Read Configuration

(6050, 6052, 6053, 6054,
6056, 6058, 6060, 6063)

@Description

Read the configuration of module on a specified address ID.

@Syntax

\$(Addr)2<CR>

| | |
|--------|--|
| \$ | Command leading code |
| (Addr) | Address ID. |
| 2 | Command code for reading configuration |

@Response

!(Addr)(TypeCode)(BaudRate)(ChecksumFalg)<CR>

or

?(Addr)<CR>

| | |
|----------------|---|
| ! | Command is valid. |
| ? | Command is invalid. |
| (Addr) | Address ID. |
| (TypeCode) | It always be 40 (Hex) for digital I/O modules. |
| (BaudRate) | Current setting of communication baud rate, refer to Table 3-1 for details. |
| (ChecksumFlag) | Current setting of check-sum flag, refer to Table 3-3. for details. |

Checksum
 0 : disable
 1 : enable

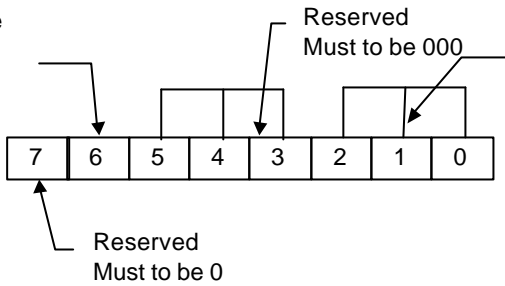

Module Type
 000: ND-6050
 001: ND-6060
 010: ND-6052
 011: ND-6053
 100: ND-6058
 101: ND-6063
 110: ND-6054
 111: ND-6056

Table 0-3 Response of check sum flag

@Example

| | |
|---------------|---------------|
| User command: | \$302<CR> |
| Response: | !30400600<CR> |

| | |
|----|------------------------|
| ! | Command is valid. |
| 30 | Address ID. |
| 40 | Digital I/O module. |
| 06 | Baud rate is 9600 bps. |
| 00 | checksum is disable. |

3.5 Read Module Name

(6050, 6052, 6053, 6054,
6056, 6058, 6060, 6063)

@Description

Read NuDAM module's name.

@Syntax

\$(Addr)M<CR>

| | |
|--------|-----------------------|
| \$ | Command leading code. |
| (Addr) | Address ID. |
| M | Read module name. |

@Response

!(Addr)(ModuleName) <CR>

or

?(Addr)<CR>

| | |
|--------------|----------------------|
| ! | Command is valid. |
| ? | Command is invalid. |
| (Addr) | Address ID. |
| (ModuleName) | NuDAM module's name. |

@Example

| | |
|---------------|-------------|
| User command: | \$30M<CR> |
| Response: | !306050<CR> |

| | |
|------|-------------------------------|
| ! | Command is valid |
| 30 | Address. |
| 6050 | ND-6050 (Digital I/O module). |

3.6 Read Firmware Version

(6050, 6052, 6053, 6054,
6056, 6058, 6060, 6063)

@Description

Read NuDAM module's firmware version.

@Syntax

\$(Addr)F<CR>

| | |
|--------|-------------------------------|
| \$ | Command leading code. |
| (Addr) | Address ID |
| F | Read module firmware version. |

@Response

!(Addr)(FirmRev) <CR>

or

?(Addr)<CR>

| | |
|-----------|----------------------------------|
| ! | Command is valid. |
| ? | Command is invalid. |
| (Addr) | Address ID. |
| (FirmRev) | NuDAM module's firmware version. |

@Example

| | |
|---------------|--------------|
| User command: | \$30F<CR> |
| Response: | !30A1.50<CR> |

| | |
|-------|-------------------|
| ! | Command is valid. |
| 30 | Address |
| A1.50 | Firmware Version |

3.7 Reset Status

(6050, 6052, 6053, 6054,
6056, 6058, 6060, 6063)

@Description

Checks the reset status of module at specified address to see whether it has been reset since the last reset status command was issued to the module.

@Syntax

\$(Addr)5<CR>

| | |
|--------|-----------------------|
| \$ | Command leading code. |
| (Addr) | Address ID. |
| 5 | Reset Status Command. |

@Response

!(Addr)(Status)<CR>

or

?(Addr)<CR>

| | |
|----------|---|
| ! | Command is valid. |
| ? | Command is invalid. |
| (Addr) | Address ID. |
| (Status) | 0 : It has not been reset since the last reset status command was issued. |
| | 1 : It has been reset since the last reset status command was issued. |

@Example

| | |
|---------------|-----------|
| User command: | \$305<CR> |
| Response: | !300<CR> |

Status is 0 means this digital I/O module has not been reset, since the last reset status command was issued.

3.8 Digital Output

(6050, 6060, 6063)

@Description

Set digital output channel value at specified address. This command is only available to modules involving the digital output function.

@Syntax

#(Addr)(ChannelNo)(OutData)<CR> (6050,6060,6063 Only)

| | |
|-------------|--|
| # | Command leading code. (1-character) |
| (Addr) | Address ID (2-character) 00 : Set value to all channels 1X : Set value to single channel |
| (ChannelNo) | First character is 1, Second character is channel number. (2-character) Set value to all channels : |
| (OutData) | Each bit is mapping to each channel number Set value to single channel : First character is 0, second character is set to value 0 or 1. (2-character) |

@Response

<CR>

or

?(Addr)<CR>

| | |
|--------|---------------------|
| > | Command is valid |
| ? | Command is invalid. |
| (Addr) | Address ID. |

@Example

| | |
|---------------|-------------|
| User command: | #300003<CR> |
| Response: | ><CR> |

| | |
|----|---|
| 30 | Address ID |
| 00 | Set output to all channels |
| 03 | 03 (00000011), Channel 0 and 1 are set ON other channels are set to OFF |

```
User command: #2F1201<CR>
Response:      ><CR>
```

```
2F           Address ID
12           1 : Set output to single channel
             2 : Output single channel is channel 2
01           Set single channel to ON
```

3.9 Digital Output (Continued)

(6056, 6058)

@Description

Set digital output channel value at specified address. This command is only available to modules involving the multiport digital output function.

@Syntax

#(Addr)T(OutDataH)(OutDataL)<CR> (6056 only)

#(Addr)T(OutDataA)(OutDataB)(OutDataC) (6058 only)

| | |
|------------|---|
| # | Command leading code. (1-character) |
| (Addr) | Address ID (2-character) |
| T | Set value to all channels |
| (OutDataH) | Each bit is mapping to each channel number from 14 to 8. (2-character) |
| (OutDataL) | Each bit is mapping to each channel number from 7 to 0. (2-character) |
| (OutDataA) | Output data for port A. Each bit is mapping to each channel number from 7 to 0. (2-character) |
| (OutDataB) | Output data for port B. Each bit is mapping to each channel number from 7 to 0. (2-character) |
| (OutDataC) | Output data for port C. Each bit is mapping to each channel number from 7 to 0. (2-character) |

*** if the port of ND-6058 is in input mode, output data to this port will be ignore.**

@Response

<CR>

or

?(Addr)<CR>

| | |
|--------|---------------------|
| > | Command is valid |
| ? | Command is invalid. |
| (Addr) | Address ID. |

@Example

User command: #30T0303<CR> (for ND-6056)

Response: ><CR>

30 Address ID
T Set output to all port
0303 0303 (0000001100000011), Channel 0, 1, 8 and 9
are set ON other channels are set to OFF

User command: #2FT010203<CR> (for ND-6058)

Response: ><CR>

2F Address ID
T Set output to all port
01 Set channel 0 of port A ON
02 Set channel 1 of port B ON
03 Set channel 0 and 1 of port C ON

3.10 Digital Output (Continued)

(6056, 6058)

@Description

Set digital output port channel value at specified address. This command is only available to modules involving the multiport digital output function.

@Syntax

#(Addr)(Port)(OutData)<CR> (6056, 6058 only)

| | |
|-----------|---|
| # | Command leading code. (1-character) |
| (Addr) | Address ID (2-character) |
| (Port) | Set value to individual port 0H: for 6056 channel 14 to 8 0L: for 6056 channel 7 to 0 0A: for 6058 port A 0B: for 6058 port B 0C: for 6058 port C (2-character) |
| (OutData) | Each bit is mapping to each channel number (2-character) |

*** if the port of ND-6058 is in input mode, output data to this port will be ignore.**

@Response

<CR>

or

?(Addr)<CR>

| | |
|--------|---------------------|
| > | Command is valid. |
| ? | Command is invalid. |
| (Addr) | Address ID. |

@Example

| | |
|---------------|--------------------------|
| User command: | #30H03<CR> (for ND-6056) |
| Response: | <CR> |

| | |
|----|-------------------------|
| 30 | Address ID |
| 0H | Set output to high byte |

03 03 (00000011), Channel 8 and 9 are set ON other channels are set to OFF

| | |
|---------------|-------------|
| User command: | #2F0A10<CR> |
| Response: | <CR> |

2F Address ID
0A Set output to port A
10 Set channel 4 of port A ON

3.11 Digital Output (Continued)

(6056, 6058)

@Description

Set direct digital output channel value at specified address. This command is only available to modules involving the multiport digital output function.

@Syntax

#(Addr)(Port)(ChNo)(OutData)<CR> (6056,6058 only)

| | |
|-----------|---|
| # | Command leading code. (1-character) |
| (Addr) | Address ID (2-character) |
| | Set direct channel value to individual port |
| | H: for 6056 channel 14 to 8 |
| (Port) | L: for 6056 channel 7 to 0 |
| | A: for 6058 port A |
| | B: for 6058 port B |
| | C: for 6058 port C (1-character) |
| (ChNo) | Channel value 7 ~ 0 |
| | 1: ON |
| (OutData) | 0: OFF |
| | (1-character) |

*** if the port of ND-6058 is in input mode, output data to this port will be ignore.**

@Response

<CR>

or

?(Addr)<CR>

| | |
|--------|---------------------|
| > | Command is valid |
| ? | Command is invalid. |
| (Addr) | Address ID. |

@Example

| | |
|---------------|--------------------------|
| User command: | #30H31<CR> (for ND-6056) |
| Response: | <CR> |

| | |
|----|---|
| 30 | Address ID |
| H | Set output to high byte |
| 3 | Channel number is 3, that is channel 11 |
| 1 | Set corresponding channel to ON |

| | |
|---------------|------------|
| User command: | #2FA20<CR> |
| Response: | <CR> |

| | |
|----|----------------------------------|
| 2F | Address ID |
| A | Set output to port A |
| 2 | Channel number is 2 |
| 0 | Set corresponding channel to OFF |

3.12 Synchronized Sampling

(6050, 6052, 6053, 6054,6058, 6060,)

@Description

Synchronized all modules to sample input values and stored the values in the module's register at the same time and use "Read Synchronized Data" command to read the data and process it one by one.

For digital I/O module, this command is only available to modules involving the digital input function, such as NuDAM-6050, NuDAM-6052, NuDAM-6053, NuDAM-6054, NuDAM-6058 and NuDAM-6060.

@Syntax

***<CR>

#

Command leading code.

**

Synchronized sampling command

@Response

Note : Synchronized sampling command **has NO response**.

@Example

User command: ***<CR>

Synchronized sampling command **has no response**.

3.13 Read Synchronized Data

(6050, 6052, 6053,6054, 6058, 6060)

@Description

After a synchronized sampling command#** was issued, you can read the input value that was stored in the addressed module's register and use same method to process other module's data one by one.

@Syntax

\$(Addr)4<CR>

| | |
|--------|-------------------------|
| \$ | Command leading code. |
| (Addr) | Address ID. |
| 4 | Read synchronized data. |

@Response

ND-6050 module response :

!(Status)(DataOut)(DataIn)00<CR>

ND-6052 module response :

!(Status)(DataIn)0000<CR>

ND-6053 module response :

!(Status)(DataInH)(DataInL)00<CR>

ND-6054 module response :

!(Status)(DataInH)(DataInL)00<CR>

ND-6058 module response :

!(Status)(IOFlag)(DIIn)(DataInA)(DataInB)(DataInC)<CR>

ND-6060 module response :

!(Status)(DataOut)(DataIn)00<CR>

or

?(Addr)<CR>

| | |
|---|---------------------|
| ! | Command is valid. |
| ? | Command is invalid. |

| | |
|-----------|--|
| | 0 : Data has been sent at least once before. |
| (Status) | 1 : Data has been sent for the first time since a synchronized sampling command was issued.(1-character) |
| | Status of programmable I/O |
| | 0x00: A(O/P) B(O/P) CH(O/P) CL(O/P) |
| | 0x01: A(O/P) B(O/P) CH(O/P) CL(I/P) |
| | 0x02: A(O/P) B(O/P) CH(I/P) CL(O/P) |
| | 0x03: A(O/P) B(O/P) CH(I/P) CL(I/P) |
| | 0x04: A(O/P) B(I/P) CH(O/P) CL(O/P) |
| | 0x05: A(O/P) B(I/P) CH(O/P) CL(I/P) |
| | 0x06: A(O/P) B(I/P) CH(I/P) CL(O/P) |
| | 0x07: A(O/P) B(I/P) CH(I/P) CL(I/P) |
| (IOFlag) | 0x08: A(I/P) B(O/P) CH(O/P) CL(O/P) |
| | 0x09: A(I/P) B(O/P) CH(O/P) CL(I/P) |
| | 0x0A: A(I/P) B(O/P) CH(I/P) CL(O/P) |
| | 0x0B: A(I/P) B(O/P) CH(I/P) CL(I/P) |
| | 0x0C: A(I/P) B(I/P) CH(O/P) CL(O/P) |
| | 0x0D: A(I/P) B(I/P) CH(O/P) CL(I/P) |
| | 0x0E: A(I/P) B(I/P) CH(I/P) CL(O/P) |
| | 0x0F: A(I/P) B(I/P) CH(I/P) CL(I/P) |
| | *I/P input mode, O/P output mode. |
| (DataOut) | Value of digital output channel. (2-character) |
| (DataIn) | Value of digital input channel. (2-character) |
| (DIn) | Value of dedicated digital input channel 3-0 for ND-6058. The first character is 0 (2-character) |
| (DataInH) | Value of digital input channel 15-8 (2-character) |
| (DataInL) | Value of digital input channel 7-0 (2-character) |
| (DataInA) | Value of port A channel 7-0 (2-character) |
| (DataInB) | Value of port B channel 7-0 (2-character) |
| (DataInC) | Value of port C channel 7-0 (2-character) |

@Examples

Example for NuDAM-6050 :

```
User command:  $304<CR>
Response:       !1065200<CR>
```

```
!           Command is valid.
1           Data has not been sent before.
06          06 (00000110) means digital output channel 1,2
           are ON, channel 0,3,4,5,6,7 are OFF.
52          52(01010010) means digital input channel 1,4,
           6 are HIGH, channel 0,2,3,5,7 are LOW..
```

Example for NuDAM-6058 :

```
User command:  $304<CR>
Response:       !10C0F010203<CR>
```

```
!           Command is valid.
1           Data has not been sent before.
0C          Port A and B are input mode, high and low half
           byte of port C are output mode.
0F          Channel 0,1,2,3 of digital input is HIGH.
01          01 (00000001) means port A digital input
           channel 0 is HIGH, others are LOW.
02          02 (00000010) means port B digital input
           channel 1 is HIGH, others are LOW.
03          03 (00000011) mean port C digital output
           channel 0,1 are ON, others are OFF.
```

3.14 Digital Input

(6050, 6052, 6053, 6054, 6058, 6060)

@Description

Read the digital input channel value and readback the digital output channel value.

@Syntax

\$(Addr)6<CR>

| | |
|--------|-----------------------------|
| \$ | Command leading code. |
| (Addr) | Address ID |
| 6 | Digital data input command. |

@Response

ND-6050 module response :

!(DataOut)(DataIn)00<CR>

ND-6052 module response :

!(DataIn)0000<CR>

ND-6053 module response :

!(DataInH)(DataInL)00<CR>

ND-6054 module response :

!(DataInH)(DataInL)00<CR>

ND-6056 module response :

!(DataOutH)(DataOutL)00<CR>

ND-6058 module response :

!(IoFlag)(DataIn)(DataA)(DataB)(DataC)<CR>

ND-6060 module response :

!(DataOut)(DataIn)00<CR>

ND-6063 module response :

!(DataOutH)0000<CR>

or

?(Addr)<CR>

| | |
|------------|---|
| ! | Command is valid. |
| ? | Command is invalid. |
| (DataOut) | Value of digital output channel. (2-character) |
| (DataIn) | Value of digital input. (2-character) |
| (DataInH) | Value of digital input channel 15-8. (2-character) |
| (DataInL) | Value of digital input channel 7-0. (2-character) |
| (DataOutH) | Value of digital output channel 15-8. (2-character) |
| (DataOutL) | Value of digital output channel 7-0. (2-character) |
| (DataA) | Value of digital channel 7-0. (2-character) |
| (DataB) | Value of digital channel 7-0. (2-character) |
| (DataB) | Value of digital channel 7-0. (2-character) |
| | Status of programmable I/O |
| | 0x00: A(O/P) B(O/P) CH(O/P) CL(O/P) |
| | 0x01: A(O/P) B(O/P) CH(O/P) CL(I/P) |
| | 0x02: A(O/P) B(O/P) CH(I/P) CL(O/P) |
| | 0x03: A(O/P) B(O/P) CH(I/P) CL(I/P) |
| | 0x04: A(O/P) B(I/P) CH(O/P) CL(O/P) |
| | 0x05: A(O/P) B(I/P) CH(O/P) CL(I/P) |
| | 0x06: A(O/P) B(I/P) CH(I/P) CL(O/P) |
| | 0x07: A(O/P) B(I/P) CH(I/P) CL(I/P) |
| (IOFlag) | 0x08: A(I/P) B(O/P) CH(O/P) CL(O/P) |
| | 0x09: A(I/P) B(O/P) CH(O/P) CL(I/P) |
| | 0x0A: A(I/P) B(O/P) CH(I/P) CL(O/P) |
| | 0x0B: A(I/P) B(O/P) CH(I/P) CL(I/P) |
| | 0x0C: A(I/P) B(I/P) CH(O/P) CL(O/P) |
| | 0x0D: A(I/P) B(I/P) CH(O/P) CL(I/P) |
| | 0x0E: A(I/P) B(I/P) CH(I/P) CL(O/P) |
| | 0x0F: A(I/P) B(I/P) CH(I/P) CL(I/P) |
| | *I/P input mode, O/P output mode. |

@Example

Example for NuDAM-6050 :

```
User command:  $306<CR>
Response:       !321100<CR>
```

```
!           Command is valid.
            32 (00110010) means digital output channel
            1, 4, 5 are ON, channel 0, 2, 3, 6, 7 are OFF.

32          11 (00000011) means digital input channel 0,
            1 are HIGH and channel 2, 3, 4, 5, 6, 7 are LOW.

11          00           No used
00
```

Example for NuDAM-6058 :

```
User command:  $304<CR>
Response:       !0C0F010203<CR>
```

```
!           Command is valid.
0C          Port A and B are input mode, high and low half
            byte of port C are output mode.
0F          Channel 0,1,2,3 of digital input is HIGH.
01          01 (00000001) means port A digital input
            channel 0 is HIGH, others are LOW.
02          02 (00000010) means port B digital input
            channel 1 is HIGH, others are LOW.
03          03 (00000011) mean port C digital output
            channel 0,1 are ON, others are OFF.
```

3.14 Programmable I/O Mode Setting

(6058)

@Description

Set the programmable input or output mode for ND-6058.

@Syntax

\$(Addr)S(IOFlag)<CR> (6058 only)

| | |
|----------|-------------------------------------|
| \$ | Command leading code. |
| (Addr) | Address ID |
| S | Set programmable I/O mode |
| | Status of programmable I/O |
| | 0x00: A(O/P) B(O/P) CH(O/P) CL(O/P) |
| | 0x01: A(O/P) B(O/P) CH(I/P) CL(I/P) |
| | 0x02: A(O/P) B(O/P) CH(I/P) CL(O/P) |
| | 0x03: A(O/P) B(O/P) CH(I/P) CL(I/P) |
| | 0x04: A(O/P) B(I/P) CH(O/P) CL(O/P) |
| | 0x05: A(O/P) B(I/P) CH(O/P) CL(I/P) |
| | 0x06: A(O/P) B(I/P) CH(I/P) CL(O/P) |
| (IOFlag) | 0x07: A(O/P) B(I/P) CH(I/P) CL(I/P) |
| | 0x08: A(I/P) B(O/P) CH(O/P) CL(O/P) |
| | 0x09: A(I/P) B(O/P) CH(O/P) CL(I/P) |
| | 0x0A: A(I/P) B(O/P) CH(I/P) CL(O/P) |
| | 0x0B: A(I/P) B(O/P) CH(I/P) CL(I/P) |
| | 0x0C: A(I/P) B(I/P) CH(O/P) CL(O/P) |
| | 0x0D: A(I/P) B(I/P) CH(O/P) CL(I/P) |
| | 0x0E: A(I/P) B(I/P) CH(I/P) CL(O/P) |
| | 0x0F: A(I/P) B(I/P) CH(I/P) CL(I/P) |
| | *I/P input mode, O/P output mode. |

@Response

!(Addr)<CR>

or

?(Addr)<CR>

| | |
|--------|---------------------|
| ! | Command is valid. |
| ? | Command is invalid. |
| (Addr) | Address ID |

@Example

User command: \$060C<CR>

Response: !06<CR>

! Command is valid.

0C Port A and B are input mode, high and low half
byte of port C are output mode.

3.15 Read Leading Code Setting

(6050, 6052, 6053, 6054,
6056, 6058, 6060, 6063)

@Description

Read command leading code setting and host watchdog status.

@Syntax

~(Addr)0<CR>

| | |
|--------|------------------------------------|
| ~ | Command leading code. |
| (Addr) | Address ID |
| 0 | Read command leading code setting. |

@Response

!(Addr)(Status)(C1)(C2)(C3)(C4)(C5)(C6)<CR>

or

?(Addr)<CR>

| | |
|----------|---|
| ! | Command is valid. |
| ? | Command is invalid. |
| (Addr) | Address ID (2-character) |
| | Bit 0 : Reserved |
| (Status) | Bit 1 : Power failure or watchdog failure Bit 2 : Host watchdog is enable Bit 3 : Host failure |
| (C1) | Leading code 1, for read configuration status, firmware version, etc. default is \$. (1-character) |
| (C2) | Leading code 2, for read synchronize sampling, digital output ,default is #. (1-character) |
| (C3) | Leading code 3, for change configuration. default is %. (1-character) |
| (C4) | Leading code 4, for read alarm status, enable alarm, etc. default is @. (1-character) |
| (C5) | Leading code 5, for read command leading code, change command leading code, etc. default is ~. (1-character) |
| (C6) | Leading code 6, this leading code is reserved. |

Default is *. (1-character)

@Example

| | |
|---------------|-------------------|
| User command: | ~060<CR> |
| Response: | !0600\$#%@~* <CR> |

Command leading code setting is \$#%@~* for module address ID is 06, current status is factory default setting.

3.16 Change Leading Code Setting

(6050, 6052, 6053, 6054,
6056, 6058, 6060, 6063)

@Description

User can use this command to change command leading code setting as he desired.

@Syntax

~(Addr)10(C1)(C2)(C3)(C4)(C5)(C6)<CR>

| | |
|--------|---|
| ~ | Command leading code. |
| (Addr) | Address ID, range (00 - FF). |
| 10 | Change command leading code setting. |
| (C1) | Leading code 1, for read configuration status, firmware version, etc. default is \$. (1-character) |
| (C2) | Leading code 2, for read synchronize sampling, digital output ,default is # . (1-character) |
| (C3) | Leading code 3, for change configuration. default is % . (1-character) |
| (C4) | Leading code 4, for read alarm status, enable alarm, etc. default is @ . (1-character) |
| (C5) | Leading code 5, for read command leading code, change leading code, etc. default is ~ . (1-character) |
| (C6) | Leading code 6, this leading code is reserved. default is * . (1-character) |

@Response

!(Addr)< CR>

or

?(Addr)<CR>

| | |
|--------|---------------------|
| ! | Command is valid. |
| ? | Command is invalid. |
| (Addr) | Address ID. |

@Examples

| | |
|---------------|--------------------------|
| User command: | ~060<CR> |
| Response: | !0600\$#%@~*<CR> |
| User command: | ~0610 A #%@~*<CR> |
| Response: | !06<CR> |
| User command: | A06F |
| Response: | !06A1.8<CR> |

Read leading code setting is \$#%@~* for module address 06 and change leading code **\$** to **A**, then use **A06F** to read firmware version of module on address 06.

*** WARNING ***

We do not recommend users to change the default setting of leading code, because it will make you confuse

The leading code change only use the command conflicts other devices on the network.

3.17 Set Host Watchdog Timer & Safety Value

(6050, 6052, 6053, 6054,
6056, 6058, 6060, 6063)

@Description

Set host watchdog timer, module will change to safety state when host is failure. Define the output value in this command.

@Syntax

~(Addr)2(Flag)(TimeOut)(SafeValue)<CR>

~(Addr)2(Flag)(TimeOut)(SafeH)(SafeL)<CR> (6056 only)

~(Addr)2(Flag)(TimeOut)(SafeA)(SafeB)(SafeC)<CR> (6058only)

| | |
|-------------|--|
| ~ | Command leading code. |
| (Addr) | Address ID, range (00 - FF). |
| 2 | Set host watchdog timer and safe state value. |
| (Flag) | 0 : Disable host watchdog timer 1 : Enable host watchdog timer (1-character) |
| (TimeOut) | Host timeout value, between this time period host must send (Host is OK) command to module, otherwise module will change to safety state. Range 01 - FF. (2-character) One unit is 100 ms 01 = 1 * 100 = 100 ms FF = 255 * 100 = 25.5 sec |
| (SafeValue) | 8 channels safety value of digital output channels when host is failure. (2-character) |
| (SafeH) | Safety value of digital output channels 14 ~ 8 when host is failure. (2-character) |
| (SafeL) | Safety value of digital output channels 7 ~ 0 when host is failure. (2-character) |
| (SafeA) | Safety value of port A channels 7 ~ 0 when host is failure while A in output mode. (2-character) |
| (SafeB) | Safety value of port B channels 7 ~ 0 when host is failure while B in output mode. (2-character) |
| (SafeC) | Safety value of port C channels 7 ~ 0 when host is failure while C in output mode. (2-character) |

@Response

!(Addr)<CR>

or

?(Addr)<CR>

| | |
|--------|---------------------|
| ! | Command is valid. |
| ? | Command is invalid. |
| (Addr) | Address ID |

@Example

Example for NuDAM-6050 :

| | |
|---------------|---------------|
| User command: | ~0621121C<CR> |
| Response: | !06<CR> |

| | |
|----|---|
| 06 | Address ID |
| 2 | Set host watchdog timer and safe state value. |
| 1 | Enable host watchdog timer. |
| | Timeout value. $0x12 = 18$ |
| 12 | $18 * 100 = 1800$ ms |
| 1C | 1C (00011100) Digital output channel DO2, DO3 and DO4 are high, the others are low. |

Example for NuDAM-6056 :

| | |
|---------------|-----------------|
| User command: | ~0621121C1C<CR> |
| Response: | !06<CR> |

| | |
|------|--|
| 06 | Address ID |
| 2 | Set host watchdog timer and safe state value. |
| 1 | Enable host watchdog timer. |
| | Timeout value. $0x12 = 18$ |
| 12 | $18 * 53.3 = 959$ ms |
| | $18 * 100 = 1800$ ms |
| 1C1C | 1C1C (0001110000011100) Digital output channel DO2, DO3, DO4, DO10, DO11, DO12 are high, the others are low. |

Example for NuDAM-6058 :

| | |
|---------------|-------------------|
| User command: | ~0621121C1C1C<CR> |
| Response: | !06<CR> |

| | |
|--------|---|
| 06 | Address ID |
| 2 | Set host watchdog timer and safe state value. |
| 1 | Enable host watchdog timer. |
| 12 | Timeout value. $0x12 = 18$ $18 * 100 = 1800$ ms |
| 1C1C1C | 1C (00011100) port A, B and C channel 2, 3 and 4 are high, the other are low. |

3.18 Read Host Watchdog Timer & Safety Value

(6050, 6052, 6053, 6054,
6056, 6058, 6060, 6063)

@Description

Read host watchdog timer setting and the safety value.

@Syntax

~(Addr)3<CR>

| | |
|--------|---|
| ~ | Command leading code. |
| (Addr) | Address ID |
| 3 | Read host watchdog setting and module safety state value. |

@Response

!(Addr)(Flag)(TimeOut)(SafeValue)<CR>

!(Addr)(Flag)(TimeOut)(SafeH)(SafeL)<CR> (6056 only)

!(Addr)(Flag)(TimeOut)(SafeA)(SafeB)(SafeC)<CR> (6058only)

or

?(Addr)<CR>

| | |
|-------------|--|
| ! | Command is valid. |
| ? | Command is invalid. |
| (Addr) | Address ID, range (00 - FF). |
| (Flag) | 0 : Host watchdog timer is disable 1 : Host watchdog timer is enable (1-character) |
| (TimeOut) | Host timeout value. Range 01 - FF. (2-character) One unit is 100 ms 01 = 1 * 100 = 100 ms FF = 255 * 100 = 25.5 sec |
| (SafeValue) | 8 channels safety state digital output value when host is failure. (2-character) |

@Example

| | |
|---------------|--------------|
| User command: | ~063<CR> |
| Response: | !061121C<CR> |

| | |
|----|--|
| 06 | Address ID |
| 1 | Host watchdog timer is enable. |
| 12 | Timeout value. $0x12 = 18$ $18 * 100 = 1800$ ms |
| 1C | 1C (00011100) Digital output channel DO3, DO4 and DO5 are high, the others are low. |

Between 1800 ms time period, if host does not send (Host is OK) then digital output will change to safety state 1C (00011100) means digital output DO3 , DO4 and DO5 is high, others are low.

3.19 Change Polarity

@Description

To change the polarity state of digital inputs and outputs of the module.

@Syntax

~(Addr)CP(State)<CR>

| | |
|---------|--|
| ~ | Command leading code (1 character) |
| (Addr) | Address ID (2 characters) |
| CP | Change Polarity (2 characters) |
| | Polarity state of digital inputs and outputs (2 characters) |
| | 00 : Do not change polarity |
| (State) | 01 : Change the polarity of digital inputs |
| | 02 : Change the polarity of digital outputs |
| | 03 : Change the polarity both the digital inputs and outputs |

@Response

!(Addr)<CR>

or

?(Addr)<CR>

| | |
|--------|---------------------|
| ! | Command is valid. |
| ? | Command is invalid. |
| (Addr) | Address ID. |

@Example

| | |
|---------------|-------------|
| User command: | ~06CP01<CR> |
| Response: | !06<CR> |

To change the polarity of digital inputs of the DI/O module which ID is 06H.

Note : For this command ,you could define the logic level which you want, For example, if the input connect to high level signal ,and you want to read back the input as a "0",then you could change the polarity to fit your requirement .

3.20 Read Polarity

@Description

To read the polarity state of digital inputs and outputs of the module.

@Syntax

~(Addr)CR<CR>

| | |
|--------|---|
| ~ | Command leading code (1 character) |
| (Addr) | Address ID (2 character) |
| CR | Read Polarity (2 character) |

@Response

!(Addr)(State)<CR>

or

?(Addr)<CR>

| | |
|---------|--|
| ! | Command is valid. |
| ? | Command is invalid. |
| (Addr) | Address ID. |
| | Polarity state of digital inputs and outputs |
| | 00 : Polarity were not changed |
| (State) | 01 : Change the polarity of digital inputs |
| | 02 : Change the polarity of digital outputs |
| | 03 : Change the polarity both the digital inputs and outputs |

@Example

| | |
|---------------|-----------|
| User command: | ~03CR<CR> |
| Response: | !0602<CR> |

Read the polarity of the DI/O module which ID is 03H.

3.21 Host is OK

@Description

When host watchdog timer is enable, host computer must send this command to every module before timeout otherwise “**host watchdog timer enable**” module’s output value will go to safety state output value.

Timeout value and safety state output value is defined in 3.14. “Set Host Watchdog Timer & Safety Value”.

@Syntax

~**<CR>

| | |
|----|-----------------------|
| ~ | Command leading code. |
| ** | Host is OK. |

@Response

Note : Host is OK command has **NO** response.

@Example

User command: ~**<CR>

Product Warranty/Service

ADLINK warrants that equipment furnished will be free from defects in material and workmanship for a period of one year from the date of shipment. During the warranty period, we shall, at our option, either repair or replace any product that proves to be defective under normal operation.

This warranty shall not apply to equipment that has been previously repaired or altered outside our plant in any way as to, in the judgment of the manufacturer, affect its reliability. Nor will it apply if the equipment has been used in a manner exceeding its specifications or if the serial number has been removed.

ADLINK does not assume any liability for consequential damages as a result from our product uses, and in any event our liability shall not exceed the original selling price of the equipment. The remedies provided herein are the customer's sole and exclusive remedies. In no event shall ADLINK be liable for direct, indirect, special or consequential damages whether based on contract of any other legal theory.

The equipment must be returned postage-prepaid. Package it securely and insure it. You will be charged for parts and labor if the warranty period is expired or the product is proves to be misuse, abuse or unauthorized repair or modification.