

IGAP-W612H+

➔ **Industrial outdoor IEEE 802.11 a/b/g/n wireless access point with 10/100/1000Base-T(X) PoE P.D., IP-67 grade**

Features

- High-Speed Air Connectivity: Dual Band in IEEE 802.11 a/b/g/n and b/g/n WLAN interface selectable and support up to 300Mbps link speed
- Highly Security Capability: WEP/WPA/WPA-PSK(TKIP,AES)/ WPA2/WPA2-PSK(TKIP,AES)/802.1X Authentication supported
- High throughput > **180Mbps** with HT40 2x2 MIMO
- High transmission power (27 dBm)
- Support **X-Roaming** < 100 ms
- Support AP/Client/Repeater Mode
- Support MAC Filtering
- Wireless connecting status monitoring
- HTTPs protocol supported for secured management
- Event Warning by Syslog, Email, SNMP Trap
- Rigid **IP-67** housing design
- Pole-mount enabled



Introduction

IGAP-W612H+ is a reliable IP-67 outdoor IEEE 802.11 a/b/g/n WLAN Access Point with 1 PoE P.D. Ethernet port. It can be configured to operate in AP/Client/Repeater mode. It is specifically designed for the toughest industrial environments. In combination with its IP-67 design and the superb management functionality, IGAP-W612H+ provides a waterproof, dust-tight connection. In addition, IGAP-W612H+ provides a high power output of 27 dBm and high throughput up to 180Mbps to satisfy far distance connection. IGAP-W612H+ provides two N-type connectors, which can install any N-type antennas to extend communication distance. You are able to configure IGAP-W612H+ by WEB interface via LAN port or WLAN interface. In addition, IGAP-W612H+ also provides P.D. feature which is fully compliant with the IEEE802.3at PoE P.D. specification to save the layout cost of the power line. IGAP-W612H+ can be easily adopted in almost all kinds of applications and provides the most rugged solutions for managing your network in outdoor. Therefore, IGAP-W612H+ is one of the best outdoor communication solutions for wireless applications

Application

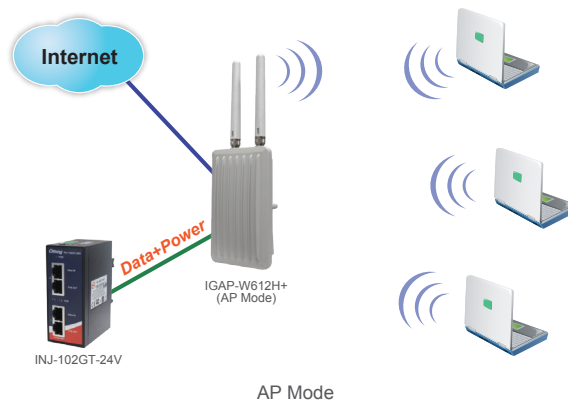

Industrial Ethernet Switch
 Industrial Media Converter
 Industrial Device Server
 Industrial Wireless Access Point
 Industrial Cellular VPN Router
 Industrial M2M Gateway
 Accessories
 Network Management Software

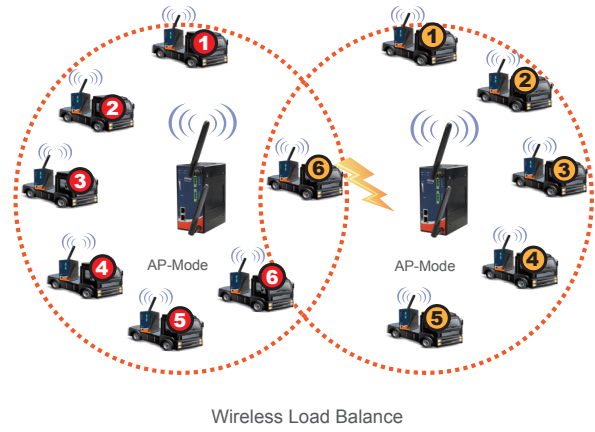
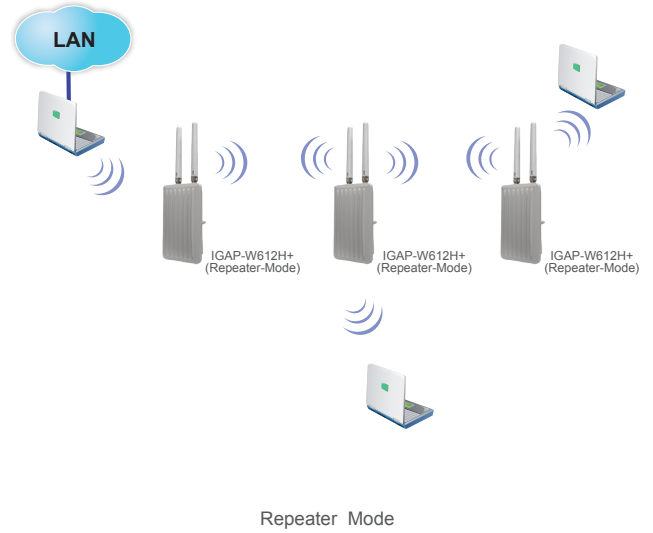
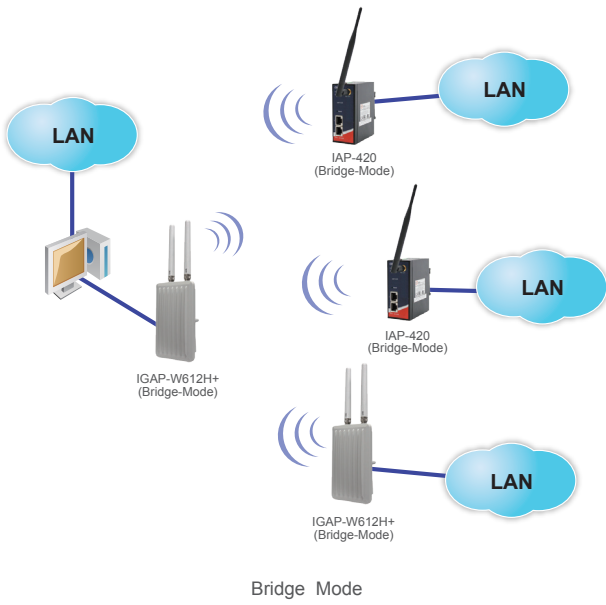

Dimensions

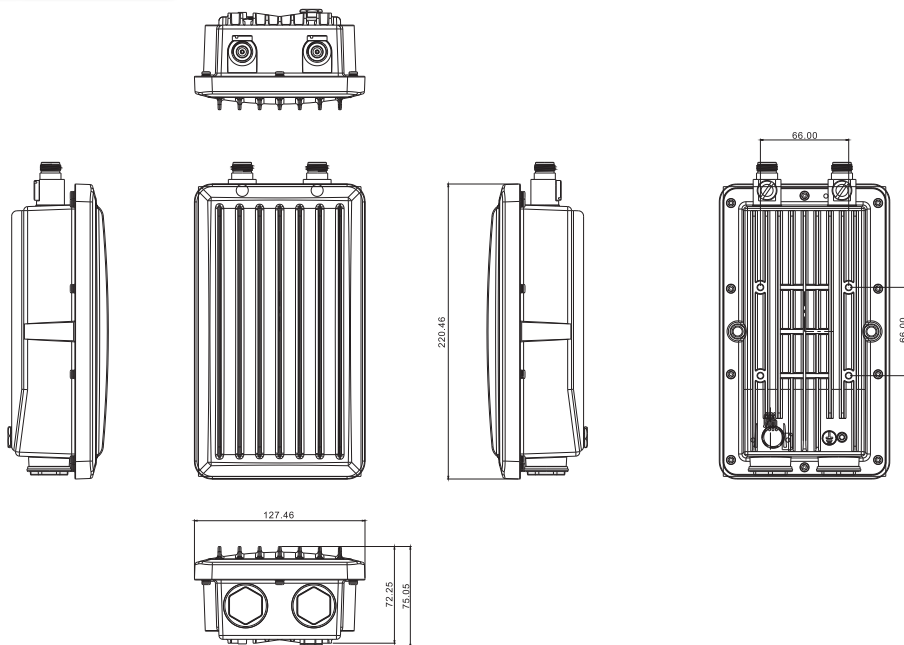

Unit =mm (Tolerance ±0.5mm)

Specifications

ORing AP Model	IGAP-W612H+
Physical Ports	
10/100/1000 Base-T(X) Ports in RJ45 Auto MDI/MDIX	1 (with PoE)
WLAN interface	
Operating Mode	AP/Client/Repeater
Antenna Connector	2 x External N-type antenna connector
Radio Frequency Type	OFDM
Modulation	IEEE802.11a: OFDM IEEE802.11b: CCK/DQPSK/DBPSK IEEE802.11g: OFDM IEEE802.11n: BPSK, QPSK, 16-QAM, 64-QAM
Frequency Band	America/FCC: 2.412~2.462 GHz (11 channels) 5.180~5.240 GHz & 5.745~5.825 GHz (9 channels) Europe CE/ETSI: 2.412~2.472 GHz (13 channels) 5.180~5.240 GHz (4 channels)
Transmission Rate	802.11b: 11, 5.5, 2, 1 Mbps; 802.11a/g: 54, 48, 36, 24, 18, 12, 9, 6 Mbps 802.11n: up to 300Mbps
Transmit Power	802.11a: 24dBm ± 1.5dBm@6Mbps, 802.11a: 12dBm ± 1.5dBm@54Mbps 802.11b: 23dBm ± 1.5dBm@1Mbps, 802.11b: 17dBm ± 1.5dBm@11Mbps 802.11g: 16dBm ± 1.5dBm@54Mbps 802.11gn HT20: 15dBm ± 1.5dBm @MCS7, 802.11gn HT40: 14dBm ± 1.5dBm @MCS7 802.11an HT20: 12dBm ± 1.5dBm @MCS7, 802.11an HT40: 11dBm ± 1.5dBm @MCS7
Receiver Sensitivity	802.11a: -92dBm ± 2dBm@6Mbps, 802.11a: -76dBm ± 2dBm@54Mbps 802.11b: -98dBm ± 2dBm@1Mbps, 802.11b: -85dBm ± 2dBm@11Mbps 802.11g: -76dBm ± 2dBm@54Mbps 802.11gn HT20: -75dBm ± 2dBm@MCS7, 802.11gn HT40: -72dBm ± 2dBm@MCS7 802.11an HT20: -74dBm ± 2dBm@MCS7, 802.11an HT40: -71dBm ± 2dBm@MCS7
Encryption Security	WEP: (64-bit, 128-bit key supported) WPA/WPA2 :802.11i(WEP and AES encryption) WPAPSK (256-bit key pre-shared key supported) 802.1X Authentication supported TKIP encryption
Wireless Security	SSID broadcast disable
Protocol Support	
Protocol	ARP, BOOTP, DHCP, DNS, HTTPs, IP, ICMP, SNMP, TCP, UDP, RADIUS, SNMP, STP (IEEE 802.1D)
LED indicators	
Power indicator	1 x LED, Green On: Power(PoE) is on and functioning Normally.
10/100/1000 Base-T(X) RJ45 port indicator	1 x LED, Green On: Port Link / Act, Blinking: data transmission
WLAN LED	3 x LED, Green for 1 x 2.4G, 1 x 5G 1x WLAN Strength: Solid > 75% Blink 2 sec/time => 74%~50% Blink 1 sec/time => 49%~25% Blink 500 msec/time => <25%
System Status LED	Green On: System ready, Blinking: System booting
Power	
Input power	48VDC from P.o.E
Power consumption (Typ.)	7 W
Physical Characteristic	
Enclosure	IP-67
Dimension (W x D x H)	220.42(W)x 127.42(D)x 75(H) mm
Weight (g)	1148g
Environmental	
Storage Temperature	-30 to 85°C (-22 to 185°F)

Industrial
Ethernet SwitchIndustrial
Media ConverterIndustrial
Device ServerIndustrial Wireless
Access PointIndustrial Cellular
VPN RouterIndustrial
M2M Gateway

Accessories

Network
Management Software

Operating Temperature	-10 to 70°C (14 to 158°F)
Operating Humidity	100% Non-condensing
Regulatory approvals	
EMC	CE EMC (EN 55024, EN 55032), FCC Part 15B
EMI	EN 55032, CISPR32, EN 61000-3-2, EN 61000-3-3, FCC Part 15B class A
EMS	EN 55024 (IEC/EN 61000-4-2 (ESD), IEC/EN 61000-4-3 (RS), IEC/EN 61000-4-4 (EFT), IEC/EN 61000-4-5 (Surge), IEC/EN 61000-4-6 (CS), IEC/EN61000-4-8(PFMF), IEC/EN 61000-4-11(DIP))
Shock	IEC60068-2-27
Free Fall	IEC60068-2-31
Vibration	IEC60068-2-6
Safety	EN60950-1
MTBF	250109 hours
Warranty	5 years

Ordering Information

IGAP-W A B C H +

Code Definition	Wireless Mode	10/100/1000Base-T(X) Port Number	Antenna Connector Number	PoE Identification
Option	- 1 : IEEE802.11 b/g - 2 : IEEE802.11 a - 3 : IEEE802.11 a/b/g - 4 : IEEE802.11 b/g/n - 5 : IEEE802.11 a/n - 6 : IEEE802.11 a/b/g/n	- "1" : 1ports - "2" : 2ports	- 0 : 0 connectors - "2" : 2 connectors	- "+" : PoE P.D. present at ETH1

Available Model	Model Name	Description
	IGAP-W612H+_US	Industrial outdoor IEEE 802.11 a/b/g/n wireless access point with 10/100/1000Base-T(X) PoE P.D., IP-67 grade, US band
	IGAP-W612H+_EU	Industrial outdoor IEEE 802.11 a/b/g/n wireless access point with 10/100/1000Base-T(X) PoE P.D., IP-67 grade, EU band

Packing List

- IGAP- W612H+ x 1
- Pole Mount Kit x 1
- RJ-45 Rubber Seal x 2
- Quick Installation Guide x 1
- N-type ANT. Rubber Seal x 2