



H/W Specifications

CPU / Memory

- CPU: ATMEL 400MHz AT91SAM9G45 w/ MMU
- Memory: 128MB DDR2 SDRAM, 256MB NAND Flash
- DataFlash@: 2MB, for system backup

Network Interface

- Type: 1 x 10/100Mbps Ethernet
- Signals: ETX+, ETX-, ERX+, ERX-
- PHY: DAVIDCOM DM9161, on-board
- Protection: 1.5KV magnetic isolation

UART

- UART 1: TX, RX, RTS, CTS, DCD, DTR, DSR, GND
- UART 2: TX, RX, RTS, CTS, GND
- UART 3: TX, RX, RTS, CTS, GND
- UART 4: TX, RX, RTS, CTS, GND
- Signal Level: CMOS / 3.3V compatible

Common UART Parameters

- Baud Rate: Up to 921.6Kbps
- Parity: None, Even, Odd, Mark, Space
- Data Bits: 5, 6, 7, 8
- Stop Bits: 1, 1.5, 2
- Flow Control: RTS / CTS, XON / XOFF, None

USB Ports

- Speed: Supports 480Mbps high-speed mode
- Host Port: 1, USB 2.0 compliant
- Host Signals: USBA+, USBA-
- Device (Client): 1, USB 2.0 compliant
- Device (Client) Signals: Uddata+, Uddata-, Udio

I2C (Inter-IC Bus)

- Signals: TWD, TWCK
- Supported Devices: EEPROM, Real Time Clock

I2S (Inter-IC Sound)

- Transmitter Signals: TSCK, TWS, TSD
- Receiver Signals: RSCK, RWS, RSD

SPI (Serial Peripheral Interface)

- Data Signals: MISO, MOSI, SPCK
- Chip Selects: CS1, CS2

SD (Secure Digital Card Interface)

- Data Signals: MCCDA, MCCK, MCDA0-MCDA3
- Aux. Signals: CD (Card Detection), WP (Write Protect)
- Compatibility: SD memory card specification 2.0
- Storage Capacity: Up to 32GB

Features

- ATMEL 400MHz AT91SAM9G45 CPU w/ MMU
- Linux kernel 2.6.38 with file system
- 128MB DDR2 SDRAM and 256MB NAND Flash
- GNU C / C++ toolchain is included
- Compact size, 50 x 80mm only
- Ultra-low power consumption, less than 2.5 Watts
- 24-bit TTL LCD interface with dimming control, supports TFT panel up to 1280 x 860 pixels
- Supports 4-wire touchscreen
- 1 x 10/100Mbps Ethernet interface, with PHY and transformer on board

Watchdog Timer

- CPU built-in watchdog timer, used by Linux kernel
- Additional watchdog timer is available for users' applications

GPIO (General-purpose I/Os)

- No. of Pins: 15, PIO0~PIO14
- Signal Level: CMOS / 3.3V compatible

AC97 Interface

- Signals: RX, TX, FS, CK
- (Note: signals are shared with GPIOs, PIO11~14)

Pre-defined I/O Pins

- Reset Button (CN1, pin#11), input
- System Reset (CN1, pin#13), input / output
- Buzzer (CN1, pin#22), output
- System Ready LED (CN1, pin#1), output
- LAN Activity LED (CN1, pin#3), output

Real Time Clock

- Chip: ST M41T81
- Backup Battery: Lithium, 48mAh, on-board
- External Battery Input: on CN1 pin#5

Debug Ports

- Type: RS-232 serial console
- Signals: Tx, Rx, GND

LCD Interface (TTL)

- Resolution: Up to 1280 x 860 TFT
- RGB Signals (24-bit): Red x 8, Green x 8, Blue x 8
- Control Signals: Dot Clock, Data Enable, H.sync, V.sync, Dimming (contrast), Backlight

Touchscreen Interface

- Type: Support 4-wire touchscreen
- Signals: Top, Bottom, Left, Right

Power Consumption

- Input Range: 3~3.6VDC (3.3V nominal)
- Consumption: 2 Watts typ.

General

- Board Dimensions (W x H): 80 x 50mm
- Pins: Total 128 pins, 2.0mm pitch
CN1: 28 pins; CN2: 50 pins; CN3: 50 pins
- Mounting Holes: x 2, 2.0mm (M2) in diameter

Front View

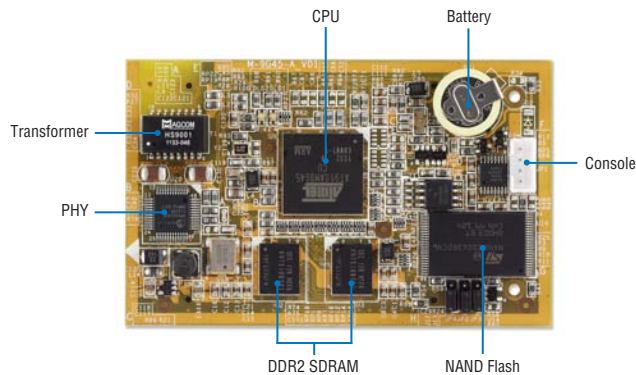

Rear View

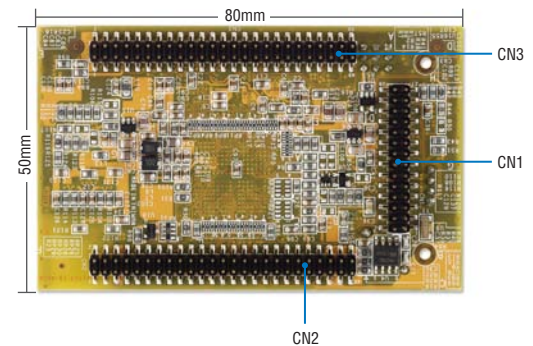

S/W Specifications

General

- OS: Linux, kernel 2.6.38
- Boot Loader: U-Boot

File Systems

- UBI, JFFS2, ETX2 / ETX3, VFAT / FAT, NFS, NTFS

Pre-installed Utilities

- bash, busybox, gtk+, x11, gpe, alsa, madplayer, psplash, sysvinit, wget, ipkg, procps (for webmin), psmics, lighttpd, vsftpd, iptables, ppp, openssh, wireless_tools, util-linux-mount / umount, usbtutils, python, jamvm, php, mysql, perl, qt4-embedded, sqlite3, snmp, Artila utility and more

Daemons Started by Default

- ssh (secured shell) with sftp
- syslog / klogd (system and kernel log)
- telnet server (disable root permission in /etc/security)
- ftp server (vsftpd)
- web server (lighttpd)
- amgrd (Artila broadcast search daemon)

Toolchain for Linux

- GCC: C / C++ PC cross compiler
- GLIBC: POSIX Library
- GUI: GTK+, X window (X11), GPE and QT4-Embedded

IPKG Package Management

- Supports ipkg to manage the package installation, upgrade and removal

Webmin System Administration

- Supports webmin for web-based system administration

Standard Device Drivers

- LCD, Real Time Clock, SD / MMC, UART, Ethernet, GPIO, Buzzer, EEPROM (ATMEL AT24C16 and compatibles), Audio out

Pre-load USB Device Drivers (Could Be Customized)

- Generic Flash drive
- IEEE-802.11b/g WiFi adapter
- 10/100Mbps Fast Ethernet adapter (RT8150)
- RS-232 adapter (Prolific PL-2303)
- Webcam
- Keyboard / Mouse
- 3G modem
- ISDN modem (CDC / ACM compatible)
- Bluetooth

Ordering Information

• M-9G45A

AT91SAM9G45 + Linux 2.6.38 System on Module with 256MB NAND Flash, 128MB DDR2 SDRAM

• M-9G45A Starter Kit

Includes one M-9G45A SoM and one carrier board with power circuitry, 1 x RS-485 port, 3 x RS-232 ports, 1 x Ethernet port, 4 x USB hosts, 1 x USB client, 1 x microSD socket, Real Time Clock, EEPROM, and local bus connector

